



Phytoremediation Potential of Selected Plants & Growth of *Oreochromis niloticus* (Linnaeus, 1758) in Aquaponic Systems

Zipporah Gichana ^{a*}

^a *Department of Environment, Natural Resources and Aquatic Sciences, School of Agriculture and Natural Resources, Kisii University, Kisii, Kenya.*

Author's contribution

The sole author designed, analyzed, interpreted and prepared the manuscript.

Article Information

DOI: 10.9734/AJFAR/2024/v26i4757

Open Peer Review History:

This journal follows the Advanced Open Peer Review policy. Identity of the Reviewers, Editor(s) and additional Reviewers, peer review comments, different versions of the manuscript, comments of the editors, etc are available here: <https://www.sdiarticle5.com/review-history/115618>

Original Research Article

Received: 12/02/2024

Accepted: 16/04/2024

Published: 20/04/2024

ABSTRACT

Aquaponic systems use plants' natural ability to absorb nutrients from aquaculture wastewater. This improves water quality for fish and promotes plant growth, resulting in a sustainable and efficient food production method. However, the nutrient removal capacity of many plant species within aquaponics remains underexplored. This study investigated the potential of three plant species: sweet wormwood (*Artemisia annua*), pumpkin (*Cucurbita pepo*) and amaranth (*Amaranthus dubius*) for biofiltration within a media-based aquaponic system. In addition, the growth performance of plants and Nile tilapia (*Oreochromis niloticus*) within the system was evaluated. *Artemisia annua* recorded significantly higher removal rates for ammonia ($52.5 \pm 19.9\%$), nitrate ($61.6 \pm 9.02\%$), and nitrite ($41.9 \pm 8.7\%$) compared to other plant species. In contrast, *C. pepo* exhibited the lowest nutrient removal efficiency. Most water quality parameters, except for ammonia and dissolved oxygen, remained within the optimal range for *O. niloticus* growth during the experiment. Significantly higher ($P < 0.05$) fish growth rates (0.33 ± 0.006 g/day) were observed

*Corresponding author: Email: zippgichana@gmail.com;

in *A. annua* than other treatments. Similarly, *A. annua* produced the highest plant yield (0.49 ± 0.02 kg/m²), while *C. pepo* yielded the least (0.29 ± 0.00 kg/m²). All the studied plants reduced aquaponic system waste, with *A. annua* exhibiting significantly higher biofiltration efficiency, promoting increased fish growth and plant yield. This demonstrates their potential for sustainable aquaculture through wastewater treatment and healthy fish production in media-based systems.

Keywords: Aquaponic system; nitrification; *Oreochromis niloticus*; phytoremediation; recirculating aquaculture; sustainable food production; water quality.

1. INTRODUCTION

Population growth, climate change, pollution, and resource depletion pose serious threats to global food security, prompting a renewed focus on novel food production methods [1]. In recent decades, advances in agricultural technologies have emerged with the potential to meet the increasing demand for food in a growing global population [1,2-3]. One such promising technology is aquaponics. Aquaponics, a closed-loop system integrating recirculating aquaculture (fish farming) and hydroponics (soilless plant cultivation), is gaining traction as a sustainable food production method due to its potential for water conservation, reduced reliance on chemical fertilizers, and increased food production in controlled environments. However, ongoing research and development are crucial to optimize its design, improve efficiency, and address limitations for broader global adoption [4,5,2]. In aquaponic systems, effluent from the aquaculture subsystem, enriched with dissolved nutrients from fish waste, serves as a nutrient source for plants cultivated in the hydroponic unit. Microbial processes and plant uptake effectively reduce dissolved nutrient concentrations within the recirculating water, consequently improving water quality parameters and fostering a favorable environment for fish health [6-9,1-2].

Several studies have documented the well-established synergistic interaction between recirculating aquaculture systems (RAS) and hydroponics, highlighting the capacity of plants to use nutrient-rich aquaculture effluent for growth while simultaneously improving water quality parameters [6,8,10-17,1-2]. However, optimizing this synergy requires the strategic selection of plant species with specific characteristics. In the context of aquaponics, plant selection prioritizes cultivars with rapid maturation cycles and a high level of adaptation to the controlled aquaponic environment and the prevailing local climatic conditions [15,16]. Continued research is critical to expand the range of plant varieties available to aquaponic practitioners, allowing for the selection

of species that optimize production efficiency, resource utilization, and overall system sustainability.

This study evaluated the suitability of sweet wormwood (*Artemisia annua*), Pumpkin (*Cucurbita pepo*) and amaranth (*Amaranthus dubius*) for integration into aquaponic systems. *Artemisia annua* is a native Chinese medicinal herb with documented adaptation to subtropical climates, such as Kenya [18]. Notably, this species holds significant medical importance as the source of artemisinin, a key component of artemisinin-based combination therapy (ACT), the primary treatment for malaria [18]. *Cucurbita pepo* and *Amaranthus dubius* are Kenyan indigenous vegetables with established economic value (Abukutsa Onyango, 2007). These species are in high demand in both domestic and export markets, presenting an opportunity for local farmers in developing countries to increase their income [18,19]. The potential for aquaponic systems to address this demand is promising, as these systems offer the potential for high crop yields while minimizing pest infestations and eliminating the need for chemical inputs [8].

Previous research has documented the successful cultivation of *A. annua* within aquaponic systems, attributing this success to its extensive root network [4]. This extensive root structure offers a substantial surface area for the colonization of nitrifying and denitrifying bacteria, which are essential for the biofiltration process [8,3,20]. However, a more comprehensive understanding of its biofiltration efficacy and growth performance within this specific environment remains elusive. This study aims to address this knowledge gap by evaluating: (1) the comparative growth performance of *A. annua*, *C. pepo*, and *A. dubius*; (2) the influence of these plant species on water quality parameters; and (3) the corresponding effects on the growth performance of *O. niloticus* within a media-based aquaponic system.

2. MATERIALS AND METHODS

2.1 Study Location and Components

The experiment was conducted for 60 days at Aqualife fish farm, Machakos located at latitude -1.525134° and longitude 37.185891° . The study compared the growth and yield performance of *A. annua*, *C. pepo*, *A. dubius* and *O. niloticus* in an aquaponic system. *Cucurbita pepo* and *A. dubius* were obtained from a Kenyan supplier (Simlaw Seeds) while *A. annua* seeds were sourced from Anamed International e.V. (Schafweide, Germany) due to their superior qualities, which included increased yield, disease resistance, and overall plant health, which were not present in locally available varieties. Monosex (all-male) fingerlings of *O. niloticus* were obtained from the Aqualife Fish Farm.

2.2 Experimental set up and Design

The experiment consisted of three treatments and three replicates representing different plant species (*A. annua*, *C. pepo* and *A. dubius*). The treatments were systematically assigned to nine identical, coupled aquaponic systems under a greenhouse to ensure consistent environmental conditions for fish and plant growth (Fig. 1). Each system comprised three interconnected

components: 500 L cylindrical plastic fish tanks, a rectangular hydroponic unit with a volume of 0.1125 m^3 for plant growth, and a two-stage biofiltration system for water treatment. The first stage of biofiltration employed a 210 L plastic barrel filled with sand particles of varying sizes to remove solid waste materials. The second stage utilized another 210 L plastic barrel filled with thoroughly rinsed and sun-dried pumice stones as a biofilter substrate for promoting the growth of beneficial nitrifying bacteria. A cold start method was implemented to activate the biofilter. This involved stocking the tanks with 50 *O. niloticus* fish one month prior to the start of the experiment. The introduction of fish supported the development of a natural population of nitrifying bacteria within the biofilter media. Fish waste products provided an initial source of ammonia, which is the primary energy source for the bacteria, thereby promoting their growth [21]. The initial average body weights of fish across treatments were: $92.8 \pm 4.2 \text{ g}$ (*C. pepo*), $103.4 \pm 8.1 \text{ g}$ (*A. annua*), and $99.8 \pm 6.3 \text{ g}$ (*A. dubia*). This resulted in stocking densities of 4.7 kg/m^3 , 5.56 kg/m^3 , and 5.25 kg/m^3 in *C. pepo*, *A. annua* and *A. dubius* treatments respectively. To ensure adequate nutrient availability for plant growth within the aquaponic system, fish $> 90 \text{ g}$ were selected due to their enhanced waste production.

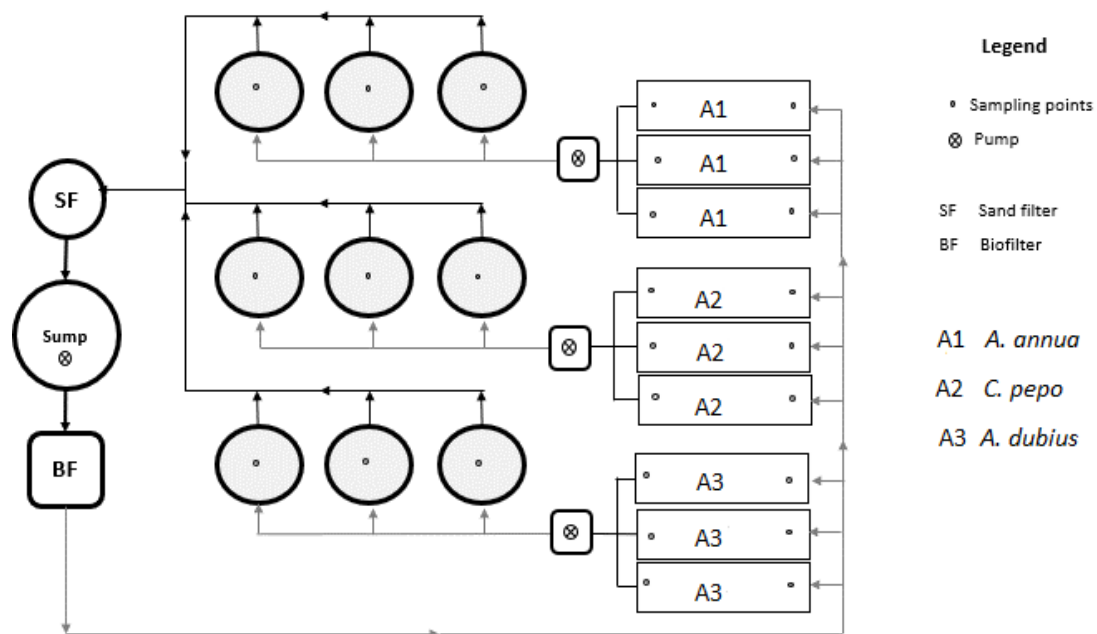

Fig. 1. A schematic diagram of the experimental aquaponics system. (not to scale). fish tanks are represented by grey circles, whereas hydroponic subsystems are represented as rectangular boxes. the flow of water is represented by grey and black lines with arrows. grey arrows represent water inlets, while black arrows represent water outlets

An air pump (> 0.03 Mpa, 60 L/min, Aqua Forte, V-60) and porous disc diffusers were used to aerate the fish tanks and biofiltration units. To maintain efficient biofiltration and prevent clogging, the biofilter and air diffusers were subjected to bi-weekly cleaning to minimize the accumulation of fine solids. Polyvinyl chloride pipes with ball valves were installed to circulate water in the system. Ball valves were used to maintain a constant flow rate of 1.42 ± 0.23 L/min in the hydroponic subsystems. The flow rate from the hydroponic units ranged between 1.29 and 1.38 L/min. Water from the fish tanks was gravity-fed through the sand filter to the sump. A centrifugal pump (DPP 60, 0.5 HP, 2500L/hr, 0.37kW) delivered effluent water from the sump (6 ± 0.24 L/min) to the biological filter. The filtered water was then gravity-fed back into the fish tanks and hydroponic subsystems. During fish sampling, approximately half of the culture water in each fish tank was replaced with clean water biweekly. Each hydroponic subsystem's outlet was designed as a bell siphon, with auto-mechanical water movement initiating the flood and drain mechanism adapted from Bruno [22] (Fig. 2).

2.3 Water Quality Parameters

Selected water quality parameters (temperature, pH, dissolved oxygen, and conductivity) were measured *insitu* twice daily (0900 and 1600 hrs) in the fish tanks and hydroponic subsystems using Hach probes (HACH HQ40d Portable meter, Loveland, Colorado, USA). Water samples were collected in triplicate every two weeks from the fish tanks, inlet, and outlet of the hydroponic subsystems for a period of two months. The samples were analysed for ammonia, nitrate, nitrite and phosphorus according to standard methods [23] using benchtop Hanna multiparameter photometer (HI83200). Nutrient (ammonia, nitrite, nitrate and phosphorus) removal efficiencies of the experimental plants were calculated as the change in nutrient concentration in the hydroponic subsystem inlets (treated water exits the biofilters) and outlets (treated water exits the hydroponic subsystems) [6].

$$\text{Nutrient removal efficiency (\%)} = \frac{C_i - C_e}{C_i} \times 100 \quad (1)$$

where C_i = concentration of inlet and C_e = concentration of outlet.

2.4 Fish and Aquaponic Plants

Fish were broadcast fed twice a day (09:00h and 16:00h) to satiation with 30% crude protein commercial pelleted feed (Raanan, Israel) diet during the study period. All fish in each tank were sampled biweekly and body weight and standard length (SL) recorded. Fish were weighed biweekly to reduce handling stress and track weight changes. The weight was recorded to the nearest 0.1 g and the mean weight calculated. Fish were harvested after 60 days, and final wet weight taken and recorded. Fish performance was evaluated using standard growth performance indices such as weight gain, specific growth rate (SGR) feed conversion ratio (FCR) and survival rate (SR). The performance indices were calculated using the following equations.

$$\text{Weight gain (g)} = \text{Final weight (g)} - \text{initial weight (g)} \quad (2)$$

$$FCR = \frac{\text{Total weight of dry feed given (g)}}{\text{Total weight gain (g)}} \quad (3)$$

$$SR (\%) = \frac{N_0 - N_t}{N_0} \quad (4)$$

$$SGR = \frac{\ln W_f - \ln W_i}{t} \times 100 \quad (5)$$

where N_0 and N_t are fish numbers at time 0 and at time t and W_i and W_f are initial and final mean wet weight in g; \ln = natural logarithm; t = time in days.

Three weeks before the start of the experiment, *C. pepo*, *A. annua* and *A. dubius* seeds were sown in three seedling trays filled with loam soil to ensure strong root development and optimal nutrient uptake in the aquaponic system. Healthy seedlings were then transplanted into the nine hydroponic subsystems. To minimize disruptions to the experiment, plant height (cm) was measured biweekly together with fish weight. However, plant weight (g) was measured at the start and end of the experiment. The final wet weight of all plants consisting of stems, leaves, and roots were measured after uprooting the whole plant from the hydroponic subsystem. The fresh weight was then used to determine the relative growth rate (RGR) of the plant species which was calculated based on the equation below:

$$RGR = (\ln W_2 - \ln W_1) / (t_2 - t_1) \quad (6)$$



Fig. 2. Schematic layout of a hydroponic unit with a bell siphon

where W_2 and W_1 are weights at time t_2 and t_1 , which are initial and final periods and \ln is the natural logarithm. Plant yield (kg/m^2) was calculated using the fresh weight obtained per square meter in each treatment.

2.5 Statistical Analysis

Data was presented as means and standard deviation (SD) of three replicates. Percentage data was subjected to arcsine transformation before statistical analyses. Normality and homogeneity of means were carried out using Shapiro–Wilks and Levene tests respectively. Repeated measures ANOVA was used to test the difference in nutrient removal efficiency, water quality parameters, plant growth parameters and fish growth among treatments. Post hoc multiple comparison of means was performed where there were significant differences using Tukey's HSD test. Differences between means were considered significant at $\alpha=0.05$. Statistical analysis was performed using the Statistical Package for Social Science (SPSS) Statistics for Windows (version. 21.0, IBM Corp., Armonk, NY, USA).

3. RESULTS

Table 1 presents water quality parameters in fish tanks. The three aquaponic treatments did not show significant differences ($P > 0.05$) in temperature, pH, or conductivity. Water temperature ranged from 21.2 to 24.6 °C, and pH levels varied between 6.88 and 7.77 in all systems. Dissolved oxygen levels ranged from 2.18 to 5.63 mg/L, with significantly higher levels in the *C. pepo* and *A. annua* aquaponic systems. The *C. pepo* system had significantly higher ammonia levels than the *A. annua* system, but there was no significant difference in nitrite levels.

The hydroponic inlet had significantly higher nutrient concentrations than the outlets ($P < 0.05$) (Fig. 3). Nitrate, nitrite, and phosphorus concentrations increased in the system during the sampling period. The concentration of ammonia decreased gradually reaching its lowest level at week 8 with an average value of 0.07 ± 0.06 mg/L in the *A. Annua* treatment. *A. annua* treatment showed significantly lower levels of ammonia and nitrate, but higher levels of phosphorus ($P < 0.05$). The *C. pepo* treatment recorded significantly low phosphorus concentration (1.87 ± 0.74).

Fig. 4 illustrates the effectiveness of *A. annua*, *C. pepo*, and *A. dubius* in removing nutrients from water in aquaponic systems. *A. annua* was more effective in reducing ammonia (52.5 ± 19.9 %), nitrite (41.9 ± 8.7 %), and nitrate (61.6 ± 9.02 %) levels than *C. pepo* and *A. dubius*. Conversely, the *C. pepo* system demonstrated a higher phosphorus removal efficiency (51.3 ± 32.4 %) than *A. annua* (36.2 ± 15.4 %) and *A. dubius* (43.3 ± 26.1 %).

The *A. annua* treatment significantly improved the growth performance of *O. niloticus* (final weight, weight gain, and specific growth rate) compared to *C. pepo* and *A. dubius* treatments (Table 2). Furthermore, *A. annua* system had a significantly lower feed conversion ratio ($P < 0.05$) than the other systems. Survival rates, on the other hand, showed no significant differences across treatments.

Plant growth parameters differed significantly across the three treatments (Table 3). *A. annua* had a significantly higher final weight, weight gain, and yield than *C. pepo* and *A. dubius*. Similar results were obtained for relative growth rates.

Table 1. Water quality parameters in fish tanks. Mean values (\pm standard deviations) within a row with different superscripts are significantly different ($a > b > c$, $P < 0.05$)

Parameters	Treatments		
	<i>C. pepo</i>	<i>A. annua</i>	<i>A. dubius</i>
Dissolved oxygen	5.63 \pm 0.69 ^c	4.49 \pm 0.59 ^b	4.25 \pm 0.81 ^a
Temperature ($^{\circ}$ C)	24.45 \pm 0.81 ^a	24.57 \pm 0.84 ^a	24.52 \pm 1.07 ^a
pH	7.60 \pm 0.23 ^a	7.52 \pm 0.42 ^a	7.66 \pm 0.07 ^a
Conductivity (μ S/cm)	1385.54 \pm 18.24 ^a	1391.24 \pm 15.53 ^a	1389.08 \pm 18.85 ^a
Ammonia (mg/L)	1.23 \pm 1.07 ^b	1.09 \pm 0.58 ^a	1.25 \pm 0.20 ^b
Nitrate (mg/L)	3.15 \pm 0.51 ^b	3.24 \pm 0.39 ^c	3.95 \pm 0.26 ^a
Nitrite (mg/L)	0.29 \pm 0.19 ^a	0.23 \pm 0.05 ^a	0.20 \pm 0.12 ^a
Phosphorus (mg/L)	1.87 \pm 0.74 ^a	2.19 \pm 1.00 ^b	2.00 \pm 0.88 ^b

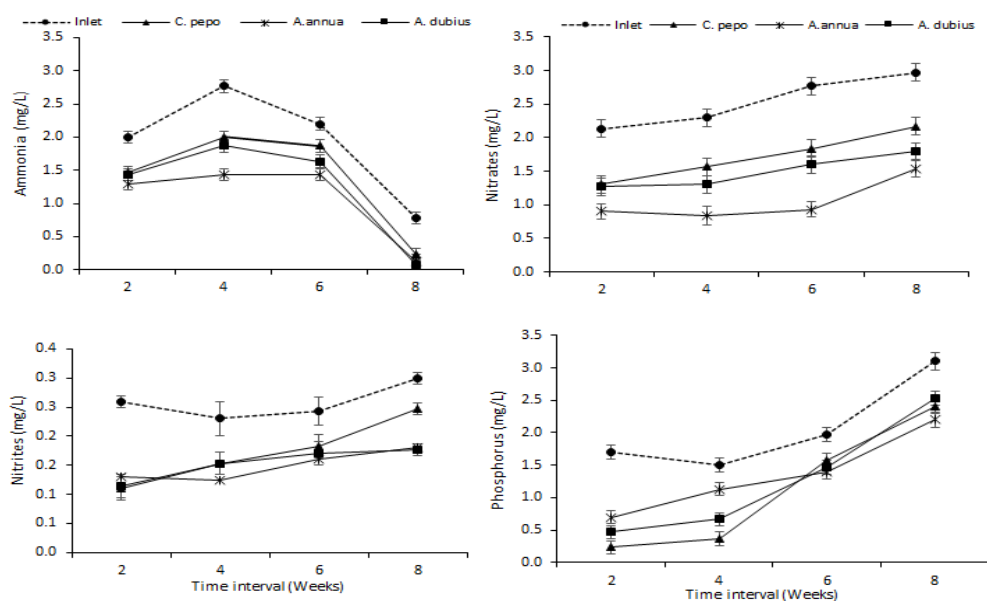

Fig. 3. Nutrient trends (ammonia, nitrate, nitrite, and phosphorus) at the hydroponic inlet and outlets (*c. pepo*, *a. annua* and *a. dubius*). Data points represent the mean of three treatment replicates and error bars indicate standard deviation.

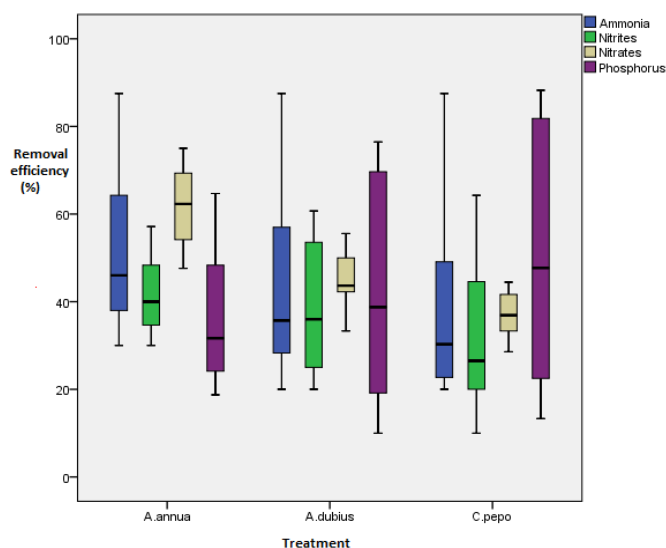

Fig. 4. Nutrient removal efficiency of plant species in the aquaponic system.

Table 2. Growth performance of *O. niloticus* in the aquaponic systems. All values are means \pm standard deviations obtained from three replicates

Parameters	Units	Treatments		
		<i>C. pepo</i>	<i>A. annua</i>	<i>A. dubius</i>
Final weight	(g)	113.50 \pm 5.54 ^a	130.25 \pm 5.76 ^b	112.21 \pm 7.64 ^a
Weight gain	(g)	32.35 \pm 4.79 ^b	26.22 \pm 4.60 ^b	15.55 \pm 1.03 ^a
Feed conversion ratio (FCR)		2.39 \pm 0.33 ^b	2.21 \pm 0.44 ^a	3.10 \pm 0.26 ^b
Specific Growth Rate (SGR)	(%/d)	0.33 \pm 0.07 ^b	0.39 \pm 0.06 ^b	0.20 \pm 0.02 ^a
Survival rate	%	88.15 \pm 4.63 ^a	92.59 \pm 3.39 ^a	82.96 \pm 3.39 ^a

Different superscript letters (a, b) within a row indicate statistically different mean values at $P < 0.05$; $a > b > c$.

Table 3. Plant growth parameters in the aquaponic systems. All values are mean \pm standard deviation obtained from three replicates

Parameters	Units	Treatments		
		<i>C. pepo</i>	<i>A. annua</i>	<i>A. dubius</i>
Final weight (Fresh)	(g)	333.33 \pm 11.72 ^b	367.00 \pm 16.09 ^c	217.67 \pm 2.52 ^a
Weight gain (Fresh)	(g)	312.40 \pm 13.05 ^b	349.20 \pm 17.28 ^c	202.00 \pm 2.00 ^a
Relative growth rate	(g/d)	0.05 \pm 0.00 ^b	0.05 \pm 0.00 ^b	0.04 \pm 0.00 ^a
Yield	(kg/m ²)	0.45 \pm 0.02 ^b	0.49 \pm 0.02 ^c	0.29 \pm 0.00 ^a

4. DISCUSSION

Most water quality parameters were within acceptable limits for *O. niloticus* and plant growth. However, two critical aquaculture parameters, ammonia and dissolved oxygen, differed slightly. Ammonia concentrations exceeded the recommended 1 mg/L level for *O. niloticus* growth [24]. This suggests the activity of the nitrifying bacteria responsible for ammonia conversion was insufficient to maintain ammonia levels at the required minimum [14,25]. Moreover, the efficiency of the biofilters were probably influenced by fine solid accumulation and low dissolved oxygen levels in the aquaponic systems. These conditions do not favour the growth of nitrifying bacteria that convert toxic ammonia to nitrates and nitrites during nitrification [26]. The observed ammonia levels could be as a result of infrequent water exchange (once every two weeks) during the study period. Minimal water exchange rates may increase the accumulation of substances such as ammonia in recirculating aquaculture systems [27].

Dissolved oxygen (DO) levels were lower than recommended range considering that oxygen should be maintained between 5 to 6 mg/L for optimum growth of fish and hydroponic plants [27]. However, *O. niloticus* can tolerate oxygen levels as low as 1.0 mg/L but levels below 3.5 mg/L can affect growth and food conversion ratio [26,3]. Low DO in aquaponic systems can be attributed to fish respiration, plant root respiration, activities of nitrifiers and

heterotrophs, and high organic loads [27]. Low oxygen levels reduce root respiration, which reduces the plant's ability to absorb water and nutrients, resulting to stunted growth [28]. Furthermore, low oxygen levels can result in root rot and nitrogen loss via denitrification [29]. Therefore, optimum DO levels should be maintained in the aquaponic systems for optimal growth of both plants and fish. Maintaining optimal dissolved oxygen (DO) levels is crucial for overall aquaponic health. Sufficient DO allows nitrifying bacteria to efficiently convert toxic ammonia into less toxic nitrates [14,25]. Efficient ammonia conversion lowers ammonia levels and improves water quality, resulting in increased growth for both fish and plants [8].

Plants play a major role in reducing nutrients in aquaponic systems because their roots provide a surface area for the attachment of bacteria responsible for the removal of both nitrogen and phosphorus from water [30]. The consistent low nutrient concentration from the hydroponic outlets is an indication of nutrient removal through the nitrification and denitrification processes in the plant roots [9,25,6]. Extensive root network of plants provides a large surface area for the attachment of more nitrifying and denitrifying bacteria which effectively reduce nutrients in the aquaponic system [31]. Therefore, developing roots of young plants at the start of the experiment probably favoured the attachment of fewer bacteria resulting in lower nitrification rates. *A. annua*'s extensive root network might have facilitated the efficient

removal of nutrients from the *A. annua*-based aquaponic system compared to other systems. The nutrient trend can also be attributed to the plant's growth stage, as plant nutrient requirements increase with each growth stage [32,3]. Nutrient removal increased during the study period due to the plants' nutrient requirements. High ammonia levels at the start of the experiment suggests that the nitrifiers had not completely colonized the young plant roots resulting in low ammonia conversion rates into usable plant nutrients. This is consistent with previous studies by Wongkiew [26,2-3] and Wafula [14] who reported high ammonia levels during the start-up periods in a recirculating aquaculture system given that the nitrifying bacteria takes time to establish and multiply. Low phosphorus concentration at the start of the experiment can be attributed to increased requirement for root development. In addition, young plants may engage in luxury uptake of phosphorus to counterbalance phosphorus need at a later stage [33].

Oreochromis niloticus exhibited higher growth in the *A. annua*-based aquaponic system compared to *C. pepo* and *A. dubius* treatments. This high performance can be attributed to *A. annua*'s effectiveness in removing nutrients from water and maintaining favorable conditions for *O. niloticus* growth and survival. However, the observed growth rate in the present study was lower (0.20 - 0.39%/day) than findings from previous aquaponic studies (0.7% and 2.5%/day) for *O. niloticus*, even with similar initial fish weights [34]. Furthermore, the feed conversion ratio (FCR) was slightly higher than the recommended range of 1.5 to 2.0 for *O. niloticus* grown in tanks [35]. Relatively high ammonia levels probably influenced the growth of *O. niloticus* in the aquaponic system. High ammonia levels above the acceptable limits (< 1 mg/L) have been shown to reduce fish growth and feed utilization efficiency [36]. Related studies indicate that recirculating systems with minimal water exchanges reduces feed intake and fish growth [37,27]. Ammonia reduces the fish's ability to extract energy from its food, resulting in a reduction in feed conversion efficiency. Even when fish maintain adequate food intake, stressful conditions have been shown to reduce feed conversion efficiency, resulting in decreased growth rates [38,39]. Our findings indicate that, while *O. niloticus* can tolerate a wide range of culture conditions, prolonged exposure to suboptimal culture conditions can lead to reduced growth and feed intake.

Plant growth performance in the current study shows that they can be successfully grown in aquaponic systems. Increased growth, weight gain, and yield were observed in *A. annua*. Gichana [37] reported similar *A. annua* results [weight gain (390.7 ± 26.8 g and yield (0.56 ± 0.03 kg/m²) in aquaponic conditions. The relatively low weight gain observed in *A. dubius*, and *C. pepo* suggests that these plants may have limited ability to extract sufficient nutrients from the aquaponic solution. This could be attributed to their smaller root systems compared to the well-developed root network of *A. Annua* [37]. Despite their different growth rates, the tested plants contributed to nutrient reduction, demonstrating their potential as biofilters in aquaponic systems. The findings from this study provide valuable insights for establishing and managing plant life in freshwater aquaponic systems. Understanding these factors enables the appropriate selection of plant species in aquaponic systems. Plants with desirable growth characteristics and efficient nutrient uptake can be selected while capitalizing on their biofiltration capabilities.

5. CONCLUSION

This study demonstrated that *C. pepo*, *A. annua*, and *A. dubius* can effectively reduce nutrients in aquaponic systems without affecting with the growth of *O. niloticus*. Notably, *A. annua*'s high nutrient uptake likely contributed to improved water quality, which might have contributed to the observed increased growth rates in *O. niloticus*. However, ammonia levels exceeded recommended levels for optimal *O. niloticus* growth. This finding emphasizes the need for additional research to improve conditions for both fish and plants. One potential area of investigation is improving the aeration system to promote nitrification, the process by which harmful ammonia is converted into less toxic nitrates. Furthermore, research is required to assess the nutritional content of the plants and the flesh quality of *O. niloticus* to ensure that they meet the established standards for aquaponic products. These quality parameters are critical to consumer acceptance and the overall success of aquaponic production.

ETHICAL APPROVAL

The study was carried out in accordance with the international, national and institutional guidelines for the care of experimental animals.

ACKNOWLEDGEMENT

This research was funded by the Austrian Partnership Programme in Higher Education and Research for Development (APPEAR), a program of the Austrian Development Cooperation (ADC) implemented by the Austrian Agency for International Cooperation in Education and Research (OeAD). The author is grateful for the technical and logistical assistance provided by the "Strengthening Regional Capacity in Research and Training in Fisheries and Aquaculture for Improved Food Security and Livelihoods in Eastern Africa" (STRECAFISH) project, the University of Eldoret (Department of Biological Sciences), and Aqualife Solutions Fish Farm. Sincere appreciation to anonymous reviewers whose insightful comments greatly improved this article.

COMPETING INTERESTS

Author has declared that no competing interests exist.

REFERENCES

1. Food and Agricultural Organisation (FAO). The state of food security and nutrition in the world report 2021. Transforming food systems for food security, improved nutrition and affordable healthy diets for all. Food and agricultural organisation, rome, italy; 2021. Available:<https://www.fao.org/3/cb4474en/cb4474en.pdf>
2. Gichana Z. Evaluation of different biofilters and selected plants for nutrient removal from a recirculating aquaculture system for Nile tilapia (*Oreochromis niloticus* Linnaeus, 1758). [Ph.D. thesis]. Vienna: University of Natural Resources and Life Sciences;2019.150p.
3. Gichana Z, Waidbacher H, Zollitsch W, Drexler S, Liti D. The potential of aquaponics as food production and nutrient recovery systems in Kenya. In: Towards Productive, Sustainable and Resilient Global Agriculture and Food Systems Conference. Wolters Kluwer CR. 2018;16 -17; Available:<https://doi.org/10.15414/isd2018.s4>.
4. Gichana Z, Liti D, Drexler S, Zollitsch W, Meulenbroek P, Wakibia J, et al. Effects of aerated and non-aerated biofilters on effluent water treatment from a small-scale recirculating aquaculture system for Nile tilapia (*Oreochromis niloticus*). Die Bodenkultur: Journal of Land Management, Food and Environment. 2019;70(4):209-219. Available:<https://doi.org/10.2478/boku2019-0019>
5. Espinosa-Moya A, Álvarez-gonzález A, Albertos-alpuche P. Growth and development of herbaceous plants in aquaponic systems. Acta Univ. Multidisp. Sci. J. 2018;28:1–8.
6. Boxman SE, Nystrom M, Capodice JC, Ergas SJ, Main KL, Trotz MA. Effect of support medium, hydraulic loading rate and plant density on water quality and growth of halophytes in marine aquaponic systems. Aquaculture Research. 2017;48 (5):2463–2477. Available:<https://doi.org/10.1111/are.13083>
7. Effendi H, Wahyuningsih S, Wardiatno Y. The use of nile tilapia (*Oreochromis niloticus*) cultivation wastewater for the production of romaine lettuce (*Lactuca sativa* L. var. longifolia) in water recirculation system. Applied Water Science. 2017;7(6):3055–3063. Available:<https://doi.org/10.1007/s13201-016-0418-z>
8. Gichana, Z. Water Quality and Growth Performance of Nile Tilapia (*Oreochromis niloticus*), Chia (*Salvia hispanica*) and Lemon Grass (*Cymbopogon citratus*) in a Media-based Aquaponics System. Asian Journal of Biolog.y. 2024;20(5):12-22.
9. Wafula AE, Gichana Z, Onchieku J, Chepkirui M, Orina SP. Opportunities and challenges of alternative local biofilter media in recirculating aquaculture systems. Journal of Aquatic & Terrestrial Ecosystems. 2023;1(1):73-81.
10. Nuwansi KKT, Verma AK, Prakash C, Tiwari VK, Chandrakant MH, Shete AP, et al. Effect of water flow rate on polyculture of koi carp (*Cyprinus carpio* var. koi) and goldfish (*Carassius auratus*) with water spinach (*Ipomoea aquatica*) in recirculating aquaponic system. Aquaculture International. 2016;24:385-393. Available:<https://doi.org/10.1007/s10499-015-9932-5>
11. Somerville C, Cohen M, Pantanella E, Stankus A, Lovatelli A. Small-scale aquaponic food production. Integrated fish and plant farming. FAO Fisheries and Aquaculture. Rome: FAO; 2014.

- Available:<https://doi.org/10.1002/pssb.201300062>
12. Bakiu R, Shehu J. Aquaponic systems as excellent agricultural research instruments in Abania. Albanian J. Agric. Sci. 2014;385-389.
 13. Rakocy JE, Masser MP, Losordo TM. Recirculating aquaculture tank production systems: Aquaponics- integrating fish and plant culture. SRAC Publication - Southern Regional Aquaculture Center. 2006; (454):16.
 14. Wafula AE, Gichana Z, Onchieku J, Orina P, Nyakeya K, Musa S. Biochar-based biofilter media improves water quality in recirculating aquaculture systems. Journal of Crops, Livestock and Pests Management. 2023;1(1):79-90
 15. Ogah SI, Salleh M, Nurul KSM, Edaroyati MWP. Biological filtration properties of selected herbs in an aquaponic system. Aquaculture Research. 2020;00:1–9. Available:<https://doi.org/10.1111/are.14526>
 16. Gichana Z, Liti D, Wakibia J, Ogello E, Drexler S. Efficiency of pumpkin (*Cucurbita pepo*), sweet wormwood (*Artemisia annua*) and amaranth (*Amaranthus dubius*) in removing nutrients from a smallscale recirculating aquaponic system. Aquaculture International. 2019;27:1767–1786.
 17. Goddek S. Three-loop Aquaponics System: Chances and Challenges. In Aquaponics Research Matters. In Proceedings of the international conference on Aquaponics Research Matters, Ljubljana, Slovenia. 2016;22. Available:<https://doi.org/10.13140/RG.2.1.3930.0246>
 18. Pulice G, Pelaz S, Matías-Hernández L. Molecular Farming in *Artemisia annua*, a Promising Approach to Improve Anti-Malarial Drug Production. Frontiers in Plant Science. 2016;7:239.
 19. Abukutsa-onyango M. The diversity of cultivated African leafy vegetables in three communities in western Kenya. African Journal of Food, Agriculture, Nutrition and Development. 2007;7(3):1–12
 20. Payne EG, Fletcher TD, Cook PL, Deletic A, Hatt BE. Processes and drivers of nitrogen removal in stormwater biofiltration. Critical Reviews in Environmental Science and Technology. 2014;44(7):796-846.
 21. Delong DP, Losordo TM. How to start a Biofilter. SRAC Publication - Southern Regional Aquaculture Center. 2012;3:1–4.
 22. Bruno RW, Chen PC, Lai V, Loc H, Delson N. Aquaponics Ebb and Flow Mechanisms ECOLIFE Foundation. MAE 156B: (Ed.), Fundamental Principles of Mechanical Design II. 2011;85.
 23. APHA. Standard Methods for the Examination of Water and Wastewater (21st ed.). Washington, DC: American Public Health Association. 2005.
 24. Hargreaves JA, Tucker CS. Managing ammonia in fish pond. SRAC Publication - Southern Regional Aquaculture Center. 2004;(4608):8.
 25. Gichana ZM, Liti D, Silke D, Waikibia J, Waidbacher H. Waste management in recirculating aquaculture system through bacteria dissimilation and plant assimilation. Aquaculture International. 2018;26:1541–1572.
 26. Wongkiew S, Hu Z, Chandran K, Lee JW, Khanal SK. Nitrogen transformations in aquaponic systems: A review. Aquacultural Engineering. 2017;76:9–19. Available:<https://doi.org/10.1016/j.aquaeng.2017.01.004>
 27. Mota VC, Limbua P, Martins CIM, Eding E, Verreth AJ. The effect of nearly closed RAS on the feed intake and growth of Nile tilapia (*Oreochromis niloticus*), African catfish (*Clarias gariepinus*) and European eel (*Anguilla anguilla*). Aquacultural Engineering. 2015; 68:1–5.
 28. Delong DP, Losordo TM, Rakocy JE. Tank Culture of Tilapia. Southern Regional Aquaculture Center. 2009;282.
 29. van Patten G. Soilless Gardening. Hydroponics Forthe Rest of Us. In D. Parke (Ed.), The Best of The Growing Edge. New Moon Publishing, Inc; 2002.
 30. Endut A, Lananan F, Abdul HS, Jusoh A, Wan Nik WN. Balancing of nutrient uptake by water spinach (*Ipomoea aquatica*) and mustard green (*Brassica juncea*) with nutrient production by African catfish (*Clarias gariepinus*) in scaling aquaponic recirculation system. Desalination and Water Treatment. 2016; 57(60):1-10. Available:<https://doi.org/10.1080/19443994.2016.1184593>
 31. Endut A, Jusoh A, Ali N, Wan Nik WB, Hassan A. A study on the optimal hydraulic loading rate and plant ratios in recirculation aquaponic system. Bioresour. Technol. 2010;101:1511–1517
 32. Jones C, Olson-rutz, K, Dinkins C. Nutrient Uptake Timing by Crops, to Assist with

- Fertilizing Decisions; Montana State University: Bozeman, MT, USA. 2015;8.
33. Buzby KM, Lin LS. Scaling aquaponic systems: Balancing plant uptake with fish output. *Aquacultural Engineering*. 2014;63: 39- 44.
Available:<https://doi.org/10.1016/j.aquaeng.2014.09.002>
34. Al-Hafedh YS, Alam A, Beltagi MS. Food production and water conservation in a recirculating aquaponic system in Saudi Arabia at different ratios of fish feed to plants. *Journal of the World Aquaculture Society*. 2008;39(4):510–520.
Available:<https://doi.org/10.1111/j.1749-7345.2008.00181.x>
35. Stickney RR. *Aquaculture: an introduction text*. Cambridge, USA: CABI publication. 2005.
36. Colt J. Water quality requirements for reuse systems. *Aquacultural Engineering*. 2006; 34(3):143–156.
Available:<https://doi.org/10.1016/j.aquaeng.2005.08.011>
37. Gichana Z, Meulenbroek P, Ogello E, Drexler S, Zollitsch W, Liti, D. et al. Growth and Nutrient Removal Efficiency of Sweet Wormwood (*Artemisia annua*) in a Recirculating Aquaculture System for Nile Tilapia. 2019;11(5): 923.
38. d'Orbcastel ER, Lemarié G, Breuil G, Petochi T, Marino G, Triplet S. Effects of Rearing Density on Sea Bass (*Dicentrarchus Labrax*) Biological Performance, Blood Parameters and Disease Resistance in a Flow Through System. *Aquat Living Resour*. 2010; 23:109–17.
DOI:10.1051/alr/2009056
39. Paspatis M, Boujard T, Maragoudaki D, Blanchard G, Kentouri M. Do Stocking Density and Feed Reward Level Affect Growth and Feeding of Self Fed Juvenile European Sea Bass? *Aquaculture*. 2003; 216:103–13.
DOI:10.1016/S0044-8486(02)00417-9 58

© Copyright (2024): Author(s). The licensee is the journal publisher. This is an Open Access article distributed under the terms of the Creative Commons Attribution License (<http://creativecommons.org/licenses/by/4.0>), which permits unrestricted use, distribution, and reproduction in any medium, provided the original work is properly cited.

Peer-review history:
The peer review history for this paper can be accessed here:
<https://www.sdiarticle5.com/review-history/115618>