



Behaviour under Moving Distributed Masses of Simply Supported Orthotropic Rectangular Plate Resting on a Constant Elastic Bi-Parametric Foundation

T. O. Awodola¹ and S. Adeoye^{1*}

¹Department of Mathematical Sciences, Federal University of Technology, Akure, Nigeria.

Authors' contributions

This work was carried out in collaboration between both authors. Author SA designed the study, performed the statistical analysis, wrote the protocol, and wrote the first draft of the manuscript. Author TOA managed the analyses of the study and the literature searches. Both authors read and approved the final manuscript.

Article Information

DOI: 10.9734/ARJOM/2020/v16i830211

Editor(s):

(1) Dr. Xingting Wang, Howard University, USA.

Reviewers:

(1) Robin, Graphic Era Hill University, India.

(2) Shivani Srivastava, Gurukul Kangri University, India.

Complete Peer review History: <http://www.sdiarticle4.com/review-history/57775>

Received: 06 April 2020

Accepted: 12 June 2020

Published: 04 July 2020

Original Research Article

Abstract

This work investigates the behavior under Moving distributed masses of orthotropic rectangular plates resting on bi-parametric elastic foundation. The governing equation is a fourth order partial differential equation with variable and singular co-efficients. The solutions to the problem are obtained by transforming the fourth order partial differential equation for the problem to a set of coupled second order ordinary differential equations using the technique of Shadnam et al[1]. This is then simplified using modified asymptotic method of Struble. The closed form solution is analyzed, resonance conditions are obtained and the results are presented in plotted curves for both cases of moving distributed mass and moving distributed force.

Keywords: Bi-parametric foundation; orthotropic; foundation modulus; critical speed; resonance; modified frequency.

*Corresponding author: E-mail: samueladebola84@gmail.com;

1 Introduction

A plate is a flat structural element for which the thickness is small compared with the surface dimensions or a plate is a structural element which is thin and flat. By "thin", it means that the plate's transverse dimension, or thickness, is small in comparison with the length and width dimensions. That is, the plate thickness is small compared to the other dimensions. A mathematical expression of this idea is:

$$\frac{T_h}{L} \ll 1 \quad (1.1)$$

where ' T_h ' represents the plate's thickness, and 'L' represents the length or width dimension. The thickness of a plate is usually constant but may be variable and is measured normal to the middle surface of the plate.

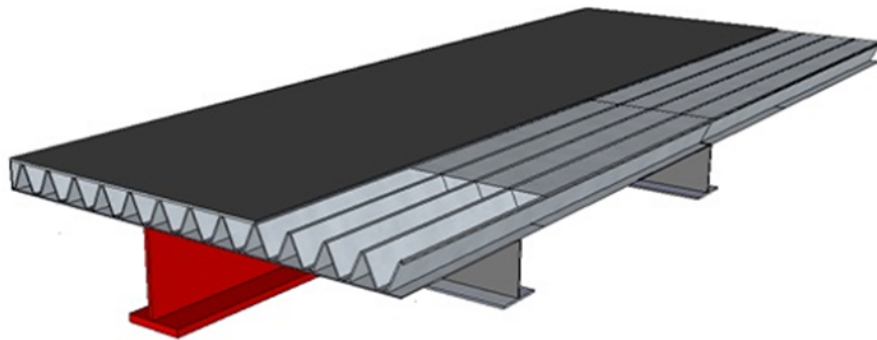

Fig. 1. Orthotropic rectangular plate

Plates subjected to in-plane loading can be solved mostly by using two-dimensional plane stress theory. On the other hand, plate theory is concerned mainly with lateral loading. There are whole lot of differences between plane stress and plate theory. One of the differences is that in the plate theory, the stress components are allowed to vary through the thickness of the plate, so that there would exist bending moments. The vast majority of the world's bridges with record long spans have utilized orthotropic steel deck systems as their superstructures. These types of decks have been used extensively. Approximately 6,000 orthotropic steel deck bridges exist in a world of about six million bridges. With the growing trend quicker construction practices with an overall longer bridge life. The other leading benefits of this bridge decking system are the minimization of dead load in the design and the rapid construction that will lessen the impact on traffic.

Tracing the plate theory to its roots, one travels back to the American revolution time. During this revolutionary period, several scientists and engineers performed numerous researches on plates. Euler [2] performed a free vibration analysis of plate problems and indicated the first impetus to a mathematical statement of plate problems. Chladni [3], a German physicist, performed experiments on horizontal plates to quantify their vibratory modes. He spattered sand on the plates, struck them with a hammer, and observed there were regular patterns formed along the nodal lines. In the works of these great scientists, the flexural rigidity was considered to be constant, D. Bernoulli [4] then attempted to theoretically justify the experimental results of Chladni using the previously developed Euler-Bernoulli bending beam theory, but his results were unable to capture the full dynamics. Malhotra [5] employed the Rayleigh-Ritz method to study vibration of orthotropic square thin plates with parabolic vibration thickness along one direction. They presented results for four types of boundary conditions. Ashour [6] examined the flexural vibration of orthotropic plates of

linearly varying thickness in one direction using the finite strip transition matrix technique. Bert and Malik [7] studied the free vibration of isotropic and orthotropic rectangular plates of linearly varying thickness in one direction by the differential quadrature method. Maljaars J Dooren Van F. and Kolstein M.H [8] examined the fatigue cracks in orthotropic bridge decks. That is to say, they all treated plates as homogeneous and isotropic materials, that their material properties remain unchanged in all directions but in reality plates are orthotropic. The same structural effects are also true of the concrete slab in a composite girder bridge, but the steel orthotropic deck is considerably lighter, and therefore allows longer span bridges to be more efficiently designed.

The vibration analysis of plates resting on elastic foundation has been the subject of many researches. Awodola [9] studied the effect of plate parameters on the vibrations under moving masses of elastically supported plate resting on bi-parametric foundation with stiffness variation. Szekrenyes [10] investigated the interface fracture in orthotropic composite plates using second order shear deformation theory. Kadari [11] analyzed buckling in orthotropic nanoscale plates resting on elastic foundations. Hu and Yao [12] studied the vibration solutions of rectangular orthotropic plates by symplectic geometry method. In the same view, Alshaya, Hunt and Rowlands [13] investigated stresses and strains in thick perforated orthotropic plates. Gbadeyan and Dada [14] found the natural frequency of rectangular plates traversed by moving concentrated masses. Barlie [15] carried out the thermo-mechanical morphological study of CFRP in different environmental conditions. Guo [16, 17] examined the fatigue life of reinforced concrete beams strengthened with CFRP under beading load. Hosseini [18] investigated the roadway metallic bridge using non-prestressed bonded and prestressed unbonded CFRP plate. In the same view, Ju [19] and Li [20] examined the fatigue life of reinforced and non-prestressed bridge deck under variable amplitude load and different adhesives. Liang [21] studied the reliability analysis of bond behavior of CFRP concrete under wet-dry cycles. Xin Yuan [22] also investigated the fatigue performance and life prediction of CFRP plate. Many researchers had solved orthotropic plate problems by numerical techniques due to its cumbersomeness, this work aims at solving the governing equation by approximate analytical techniques and also considers the effect of flexural rigidities in both x and y directions.

2 Governing Equation

The dynamic transverse displacement $W(x, y, t)$ of orthotropic rectangular plates when it is resting on a bi-parametric elastic foundation and traversed by distributed mass M_r moving with constant velocity c_r along a straight line parallel to the x-axis issuing from point $y=s$ on the y-axis with flexural rigidities D_x and D_y is governed by the fourth order partial differential equation given as

$$\begin{aligned}
 & D_x \frac{\partial^4}{\partial x^4} W(x, y, t) + 2B \frac{\partial^4}{\partial x^2 \partial y^2} W(x, y, t) + D_y \frac{\partial^4}{\partial y^4} W(x, y, t) + \mu \frac{\partial^2}{\partial t^2} W(x, y, t) - \rho h R_0 \\
 & \left[\frac{\partial^4}{\partial x^2 \partial t^2} W(x, y, t) + \frac{\partial^4}{\partial y^2 \partial t^2} W(x, y, t) \right] + K_0 W(x, y, t) - G_0 \left[\frac{\partial^2}{\partial x^2} W(x, y, t) + \frac{\partial^2}{\partial y^2} W(x, y, t) \right] \\
 & - \sum_{r=1}^N \left[M_r g H(x - ct) H(y - s) - M_r \left(\frac{\partial^2}{\partial t^2} W(x, y, t) + 2c_r \frac{\partial^2}{\partial x \partial t} W(x, y, t) + c_r^2 \frac{\partial^2}{\partial x^2} W(x, y, t) \right) \right. \\
 & \left. H(x - c_r t) H(y - s) W(x, y, t) \right] = 0
 \end{aligned} \tag{2.1}$$

where D_x and D_y are the flexural rigidities of the plate along x and y axes respectively.

$$D_x = \frac{E_x h^3}{12(1 - \nu_x \nu_y)}, \quad D_y = \frac{E_y h^3}{12(1 - \nu_x \nu_y)}, \quad B = D_x D_y + \frac{G_0 h^3}{6}$$

E_x and E_y are the Young's moduli along x and y axes respectively, G_o is the rigidity modulus, ν_x and ν_y are Poisson's ratios for the material such that $E_x\nu_y = E_y\nu_x$, ρ is the mass density per unit volume of the plate, h is the plate thickness, t is the time, x and y are the spatial coordinates in x and y directions respectively, R_o is the rotatory inertia correction factor, K_o is the foundation constant and g is the acceleration due to gravity, $H(\cdot)$ is the Heaviside function.

Rewriting equation (2.1), one obtains

$$\begin{aligned} \mu \frac{\partial^2}{\partial t^2} W(x, y, t) + \mu \omega_n^2 W(x, y, t) &= \rho h R_o \left[\frac{\partial^4}{\partial x^2 \partial t^2} W(x, y, t) + \frac{\partial^4}{\partial y^2 \partial t^2} W(x, y, t) \right] - 2B \\ &\frac{\partial^4}{\partial x^2 \partial y^2} W(x, y, t) - D_x \frac{\partial^4}{\partial x^4} W(x, y, t) - D_y \frac{\partial^4}{\partial y^4} W(x, y, t) - K_o W(x, y, t) + \mu \omega_n^2 W(x, y, t) \\ &+ G_o \left[\frac{\partial^2}{\partial x^2} W(x, y, t) + \frac{\partial^2}{\partial y^2} W(x, y, t) \right] + \sum_{r=1}^N \left[M_r g H(x - c_r t) H(y - s) - M_r \left(\frac{\partial^2}{\partial t^2} W(x, y, t) \right) \right. \\ &\left. + 2c \frac{\partial^2}{\partial x \partial t} W(x, y, t) + c_r^2 \frac{\partial^2}{\partial x^2} W(x, y, t) \right) H(x - c_r t) H(y - s) W(x, y, t) \end{aligned} \tag{2.2}$$

which can be expressed further as

$$\begin{aligned} \frac{\partial^2}{\partial t^2} W(x, y, t) + \omega_n^2 W(x, y, t) &= R_o \left[\frac{\partial^4}{\partial x^2 \partial t^2} W(x, y, t) + \frac{\partial^4}{\partial y^2 \partial t^2} W(x, y, t) \right] - \frac{2B}{\mu} \frac{\partial^4}{\partial x^2 \partial y^2} \\ &W(x, y, t) - \frac{D_x}{\mu} \frac{\partial^4}{\partial x^4} W(x, y, t) - \frac{D_y}{\mu} \frac{\partial^4}{\partial y^4} W(x, y, t) + \left[\omega_n^2 - \frac{K_o}{\mu} \right] W(x, y, t) + \frac{G_o}{\mu} \left[\frac{\partial^2}{\partial x^2} \right. \\ &\left. W(x, y, t) + \frac{\partial^2}{\partial y^2} W(x, y, t) \right] + \sum_{r=1}^N \left[\frac{M_r g \mu H(x - c_r t)}{H} (y - s) - \frac{M_r}{\mu} \left(\frac{\partial^2}{\partial t^2} W(x, y, t) + 2c \right. \right. \\ &\left. \left. \frac{\partial^2}{\partial x \partial t} \frac{\partial^2}{\partial x \partial t} W(x, y, t) + c_r^2 \frac{\partial^2}{\partial x^2} W(x, y, t) \right) H(x - c_r t) H(y - s) W(x, y, t) \right] \end{aligned} \tag{2.3}$$

where ω_n^2 is the natural frequencies, $n = 1, 2, 3, \dots$ The initial conditions, without any loss of generality, is taken as

$$W(x, y, t) = 0 = \frac{\partial}{\partial t} W(x, y, t) \tag{2.4}$$

3 Analytical Approximate Solution

In order to solve equation (2.3), one applies technique of Shadnam et al[19] which requires that the deflection of the plates be in series form as

$$W(x, y, t) = \sum_{n=1}^N \Psi_n(x, y) Q_n(t) \tag{3.1}$$

where $\Psi_n(x, y) = \Psi_{ni}(x) \Psi_{nj}(y)$ and

$$\begin{aligned} \Psi_{ni}(x) &= \sin \frac{\nu_{ni}}{L_x} x + A_{ni} \cos \frac{\nu_{ni}}{L_x} x + B_{ni} \sinh \frac{\nu_{ni}}{L_x} x + C_{ni} \cosh \frac{\nu_{ni}}{L_x} x \\ \Psi_{nj}(y) &= \sin \frac{\nu_{nj}}{L_y} y + A_{nj} \cos \frac{\nu_{nj}}{L_y} y + B_{nj} \sinh \frac{\nu_{nj}}{L_y} y + C_{nj} \cosh \frac{\nu_{nj}}{L_y} y \end{aligned} \tag{3.2}$$

The right hand side of equation (2.3) written in the form of series takes the form

$$\begin{aligned} & \sum_{n=1}^{\infty} R_0 \left[\frac{\partial^4}{\partial x^2 \partial t^2} W(x, y, t) + \frac{\partial^4}{\partial y^2 \partial t^2} W(x, y, t) \right] - \frac{2B}{\mu} \frac{\partial^4}{\partial x^2 \partial y^2} W(x, y, t) - \frac{D_x}{\mu} \frac{\partial^4}{\partial x^4} W(x, y, t) \\ & - \frac{D_y}{\mu} \frac{\partial^4}{\partial y^4} W(x, y, t) + \left[\omega_n^2 - \frac{K_0}{\mu} \right] W(x, y, t) + \frac{G_0}{\mu} \left[\frac{\partial^2}{\partial x^2} W(x, y, t) + \frac{\partial^2}{\partial y^2} W(x, y, t) \right] + \\ & \sum_{r=1}^N \left[\frac{M_r g \mu H(x - c_r t)}{H} (y - s) - \frac{M_r}{\mu} \left(\frac{\partial^2}{\partial t^2} W(x, y, t) + 2c_r \frac{\partial^2}{\partial x \partial t} W(x, y, t) + c_r^2 \frac{\partial^2}{\partial x^2} \right. \right. \\ & \left. \left. W(x, y, t) \right) H(x - c_r t) H(y - s) W(x, y, t) \right] = \sum_{n=1}^N \Phi_n(x, y) \sigma_n(t) \end{aligned} \tag{3.3}$$

On multiplying both sides of equation (3.3) by $\Psi_m(x, y)$, integrating on area A of the plate and considering the orthogonality of $\Psi_m(x, y)$, one obtains

$$\begin{aligned} \sigma_n(t) = & \frac{1}{\Delta} \sum_{n=1}^{\infty} \int_A \left[R_0 \left(\frac{\partial^4}{\partial x^2 \partial t^2} W(x, y, t) + \frac{\partial^4}{\partial y^2 \partial t^2} W(x, y, t) \right) - \frac{2B}{\mu} \frac{\partial^4}{\partial x^2 \partial y^2} W(x, y, t) - \right. \\ & \left. \frac{D_x}{\mu} \frac{\partial^4}{\partial x^4} W(x, y, t) - \frac{D_y}{\mu} \frac{\partial^4}{\partial y^4} W(x, y, t) + \left(\omega_n^2 - \frac{K_0}{\mu} \right) W(x, y, t) + \frac{G_0}{\mu} \left(\frac{\partial^2}{\partial x^2} W(x, y, t) \right. \right. \\ & \left. \left. + \frac{\partial^2}{\partial y^2} W(x, y, t) \right) + \sum_{r=1}^N \left[\frac{M_r g \mu H(x - c_r t)}{H} (y - s) - \frac{M_r}{\mu} \left(\frac{\partial^2}{\partial t^2} W(x, y, t) + 2c_r \right. \right. \\ & \left. \left. \frac{\partial^2}{\partial x \partial t} W(x, y, t) + c_r^2 \frac{\partial^2}{\partial x^2} W(x, y, t) \right) H(x - c_r t) H(y - s) W(x, y, t) \right] \Phi_m(x, y) dA \end{aligned} \tag{3.4}$$

and zero when $n \neq m$

where

$$\theta^* = \int_A \Psi_n^2(x, y) dA \tag{3.5}$$

Taking into account equation (2.4) and making use of equations (3.1) and (3.3), equation (3.4) can be re-written as

$$\begin{aligned} \Phi_n(x, y) \left[\ddot{Q}_n(t) + \omega_n^2 Q_n(t) \right] = & \frac{\Phi_n(x, y)}{\Delta} \sum_{q=1}^{\infty} \int_A \left[R_0 \left(\frac{\partial^2 \Phi_q(x, y)}{\partial x^2} \Phi_m(x, y) \ddot{Q}_q(t) + \frac{\partial^2 \Phi_q(x, y)}{\partial y^2} \right. \right. \\ & \left. \left. \Phi_m(x, y) \ddot{Q}_q(t) \right) - \frac{2B}{\mu} \frac{\partial^2 \Phi_q(x, y)}{\partial x^2 \partial y^2} \Phi_m(x, y) Q_q(t) - \frac{D_x}{\mu} \frac{\partial^4 \Phi_q(x, y)}{\partial x^4} \Phi_m(x, y) Q_q(t) - \frac{D_y}{\mu} \right. \\ & \left. \frac{\partial^4 \Phi_q(x, y)}{\partial y^4} \Phi_m(x, y) Q_q(t) + \left(\omega_n^2 - \frac{K_0}{\mu} \right) \Phi_q(x, y) \Phi_m(x, y) Q_q(t) + \frac{G_0}{\mu} \left(\frac{\partial^2 \Phi_q(x, y)}{\partial x^2} \Phi_m(x, y) \right. \right. \\ & \left. \left. Q_q(t) + \frac{\partial^2 \Phi_q(x, y)}{\partial y^2} \Phi_m(x, y) Q_q(t) \right) + \sum_{r=1}^N \left(\frac{M_r g \mu \Phi_m(x, y) H(x - c_r t)}{H} (y - s) - \frac{M_r}{\mu} \left(\Phi_q(x, y) \right. \right. \\ & \left. \left. \Phi_m(x, y) \ddot{Q}_q(t) + 2c_r \frac{\partial \Phi_q(x, y)}{\partial x} \Phi_m(x, y) \dot{Q}_q(t) + c_r^2 \frac{\partial^2 \Phi_q(x, y)}{\partial x^2} \Phi_m(x, y) Q_q(t) \right) H(x - c_r t) \right. \\ & \left. \left. H(y - s) \right) \right] dA \end{aligned} \tag{3.6}$$

On further simplification of equation (3.6), one obtains

$$\begin{aligned} \ddot{Q}_n(t) + \omega_n^2 Q_n(t) = & \frac{1}{\Delta} \sum_{q=1}^{\infty} \int_A \left[R_0 \left(\frac{\partial^2 \Phi_q(x, y)}{\partial x^2} \Phi_m(x, y) \ddot{Q}_q(t) + \frac{\partial^2 \Phi_q(x, y)}{\partial y^2} \Phi_m(x, y) \ddot{Q}_q(t) \right) \right. \\ & \left. - \frac{2B}{\mu} \frac{\partial^2 \Phi_q(x, y)}{\partial x^2 \partial y^2} \Phi_m(x, y) Q_q(t) - \frac{D_x}{\mu} \frac{\partial^4 \Phi_q(x, y)}{\partial x^4} \Phi_m(x, y) Q_q(t) - \frac{D_y}{\mu} \frac{\partial^4 \Phi_q(x, y)}{\partial y^4} \Phi_m(x, y) \right. \\ & Q_q(t) + \left(\omega_n^2 - \frac{K_0}{\mu} \right) \Phi_q(x, y) \Phi_m(x, y) Q_q(t) + \frac{G_0}{\mu} \left(\frac{\partial^2 \Phi_q(x, y)}{\partial x^2} \Phi_m(x, y) Q_q(t) + \frac{\partial^2 \Phi_q(x, y)}{\partial y^2} \right. \\ & \left. \Phi_m(x, y) Q_q(t) \right) + \sum_{r=1}^N \left(\frac{M_r g}{\mu} \Phi_m(x, y) H(x - c_r t) H(y - s) - \frac{M_r}{\mu} \left(\Phi_q(x, y) \Phi_m(x, y) \ddot{Q}_q(t) \right. \right. \\ & \left. \left. + 2c_r \frac{\partial \Phi_q(x, y)}{\partial x} \Phi_m(x, y) \dot{Q}_q(t) + c_r^2 \frac{\partial^2 \Phi_q(x, y)}{\partial x^2} \Phi_m(x, y) Q_q(t) \right) H(x - c_r t) H(y - s) \right] dA \end{aligned}$$

which is a set of coupled ordinary differential equations

Using the Fourier series representation, the Heaviside functions take the form

$$H(x - c_r t) = \frac{1}{4} + \frac{1}{\pi} \sum_{r=1}^N \frac{\sin(2n + 1)\pi(x - c_r t)}{2n + 1}, 0 < x < 1 \tag{3.7}$$

$$H(y - s) = \frac{1}{4} + \frac{1}{\pi} \sum_{r=1}^N \frac{\sin(2n + 1)\pi(y - s)}{2n + 1}, 0 < y < 1 \tag{3.8}$$

On putting equations (3.8) and (3.9) into equation (3.7) and simplifying one obtains

$$\begin{aligned} \ddot{Q}_n(t) + \omega_n^2 Q_n(t) - \frac{1}{\Delta} \sum_{q=1}^{\infty} \left[R_0 T_0 \ddot{Q}_q(t) - \frac{2B}{\mu} T_1 Q_q(t) - \frac{D_x}{\mu} T_2 Q_q(t) - \frac{D_y}{\mu} T_3 Q_q(t) + \right. \\ \left(\omega_n^2 - \frac{K_0}{\mu} \right) T_4 Q_q(t) + \frac{G_0}{\mu} T_5 Q_q(t) - \sum_{r=1}^N \frac{M_r}{\mu} \left(\left(T_6 + \frac{1}{\pi^2} \left(\sum_{j=1}^{\infty} E_1^* \frac{\cos(2j + 1)\pi c_r t}{2j + 1} - \sum_{j=1}^{\infty} E_2^* \frac{\sin(2j + 1)\pi c_r t}{2j + 1} \right) \right. \right. \\ \left. \left(\sum_{k=1}^{\infty} E_3^* \frac{\cos(2k + 1)\pi s}{2k + 1} - \sum_{k=1}^{\infty} E_4^* \frac{\sin(2k + 1)\pi s}{2k + 1} \right) + \frac{1}{4\pi} \right. \\ \left. \left(\sum_{j=1}^{\infty} E_5^* \frac{\cos(2j + 1)\pi c_r t}{2j + 1} - \sum_{j=1}^{\infty} E_6^* \frac{\sin(2j + 1)\pi c_r t}{2j + 1} \right) + \frac{1}{4\pi} \left(\sum_{k=1}^{\infty} E_7^* \frac{\cos(2k + 1)\pi s}{2k + 1} - \sum_{k=1}^{\infty} E_8^* \frac{\sin(2k + 1)\pi s}{2k + 1} \right) \right) \ddot{Q}_q(t) + 2c_r t \left(T_7 + \frac{1}{\pi^2} \left(\sum_{j=1}^{\infty} E_9^* \frac{\cos(2j + 1)\pi c_r t}{2j + 1} - \sum_{j=1}^{\infty} E_{10}^* \frac{\sin(2j + 1)\pi c_r t}{2j + 1} \right) \right. \\ \left. \left(\sum_{k=1}^{\infty} E_{11}^* \frac{\cos(2k + 1)\pi s}{2k + 1} - \sum_{k=1}^{\infty} E_{12}^* \frac{\sin(2k + 1)\pi s}{2k + 1} \right) + \frac{1}{4\pi} \left(\sum_{j=1}^{\infty} E_{13}^* \right. \right. \end{aligned}$$

$$\begin{aligned}
 & \left. \begin{aligned}
 & \frac{\cos(2j+1)\pi c_r t}{2j+1} - \sum_{j=1}^{\infty} E_{14}^* \frac{\sin(2j+1)\pi c_r t}{2j+1} \right) + \frac{1}{4\pi} \left(\sum_{k=1}^{\infty} E_{15}^* \frac{\cos(2k+1)\pi s}{2k+1} - \sum_{k=1}^{\infty} E_{16}^* \right. \\
 & \left. \frac{\sin(2k+1)\pi s}{2k+1} \right) \dot{Q}_q(t) + c_r^2 \left(T_8 + \frac{1}{\pi^2} \left(\sum_{j=1}^{\infty} E_{17}^* \frac{\cos(2j+1)\pi c_r t}{2j+1} - \sum_{j=1}^{\infty} E_{18}^* \frac{\sin(2j+1)\pi c_r t}{2j+1} \right. \right. \\
 & \left. \left. \right) \left(\sum_{k=1}^{\infty} E_{19}^* \frac{\cos(2k+1)\pi s}{2k+1} - \sum_{k=1}^{\infty} E_{20}^* \frac{\sin(2k+1)\pi s}{2k+1} \right) + \frac{1}{4\pi} \left(\sum_{j=1}^{\infty} E_{21}^* \frac{\cos(2j+1)\pi c_r t}{2j+1} \right. \right. \\
 & \left. \left. - \sum_{j=1}^{\infty} E_{22}^* \frac{\sin(2j+1)\pi c_r t}{2j+1} \right) + \frac{1}{4\pi} \left(\sum_{k=1}^{\infty} E_{23}^* \frac{\cos(2k+1)\pi s}{2k+1} - \sum_{k=1}^{\infty} E_{24}^* \frac{\sin(2k+1)\pi s}{2k+1} \right) \right) \\
 & Q_q(t) \Big] = \sum_{q=1}^{\infty} \sum_{r=1}^N \frac{M_r g}{\mu \Delta} \Phi_m(ct) \Phi_m(s)
 \end{aligned} \tag{3.9}
 \end{aligned}$$

which is the transformed equation governing the problem of an orthotropic rectangular plate resting on bi-parametric elastic foundation.

where

$$T_0 = \int_A \left[\frac{\partial^2}{\partial x^2} \Phi_q(x, y) \Phi_m(x, y) + \frac{\partial^2}{\partial y^2} \Phi_q(x, y) \Phi_m(x, y) \right] dA \tag{3.10}$$

$$T_1 = \int_A \frac{\partial^2}{\partial x^2} \left[\frac{\partial^2}{\partial x^2} \Phi_q(x, y) \right] \Phi_m(x, y) dA \tag{3.11}$$

$$T_2 = \int_A \frac{\partial^4}{\partial x^4} \left[\Phi_q(x, y) \right] \Phi_m(x, y) dA \tag{3.12}$$

$$T_3 = \int_A \frac{\partial^4}{\partial y^4} \left[\Phi_q(x, y) \right] \Phi_m(x, y) dA \tag{3.13}$$

$$T_4 = \int_A \Phi_q(x, y) \Phi_m(x, y) dA \tag{3.14}$$

$$T_5 = \int_A \left[\frac{\partial^2}{\partial x^2} \Phi_q(x, y) + \frac{\partial^2}{\partial y^2} \Phi_q(x, y) \right] \Phi_m(x, y) dA \tag{3.15}$$

$$T_6 = \frac{1}{16} \int_A \Phi_q(x, y) \Phi_m(x, y) dA \tag{3.16}$$

$$E_1^* = \int_A \Phi_q(x, y) \Phi_m(x, y) \sin(2j+1)\pi x dA \tag{3.17}$$

$$E_2^* = \int_A \Phi_q(x, y) \Phi_m(x, y) \cos(2j+1)\pi x dA \tag{3.18}$$

$$E_3^* = \int_A \Phi_q(x, y) \Phi_m(x, y) \sin(2k+1)\pi y dA \tag{3.19}$$

$$E_4^* = \int_A \Phi_q(x, y) \Phi_m(x, y) \cos(2k+1)\pi y dA \tag{3.20}$$

$$E_5^* = E_1^*, \quad E_6^* = E_2^*, \quad E_7^* = E_3^*, \quad E_8^* = E_4^* \tag{3.21}$$

$$T_7 = \frac{1}{16} \int_A \frac{\partial}{\partial x} \Phi_q(x, y) \Phi_m(x, y) dA \tag{3.22}$$

$$E_9^* = \int_A \frac{\partial}{\partial x} \left(\Phi_q(x, y) \right) \Phi_m(x, y) \sin(2j+1)\pi x dA \tag{3.23}$$

$$E_{10}^* = \int_A \frac{\partial}{\partial x} \left(\Phi_q(x, y) \right) \Phi_m(x, y) \cos(2j + 1)\pi x dA \quad (3.24)$$

$$E_{11}^* = \int_A \frac{\partial}{\partial x} \left(\Phi_q(x, y) \right) \Phi_m(x, y) \sin(2k + 1)\pi y dA \quad (3.25)$$

$$E_{12}^* = \int_A \frac{\partial}{\partial x} \Phi_q(x, y) \Phi_m(x, y) \cos(2k + 1)\pi y dA \quad (3.26)$$

$$E_{13}^* = E_9^*, \quad E_{14}^* = E_{10}^*, \quad E_{15}^* = E_{11}^*, \quad E_{16}^* = E_{12}^* \quad (3.27)$$

$$T_8 = \frac{1}{16} \int_A \frac{\partial^2}{\partial x^2} \left(\Phi_q(x, y) \right) \Phi_m(x, y) dA \quad (3.28)$$

$$E_{17}^* = \int_A \frac{\partial^2}{\partial x^2} \left(\Phi_q(x, y) \right) \Phi_m(x, y) \sin(2j + 1)\pi x dA \quad (3.29)$$

$$E_{18}^* = \int_A \frac{\partial^2}{\partial x^2} \left(\Phi_q(x, y) \right) \Phi_m(x, y) \cos(2j + 1)\pi x dA \quad (3.30)$$

$$E_{19}^* = \int_A \Phi_q(x, y) \Phi_m(x, y) \sin(2k + 1)\pi y dA \quad (3.31)$$

$$E_{20}^* = \int_A \frac{\partial^2}{\partial x^2} \left(\Phi_q(x, y) \right) \Phi_m(x, y) \cos(2k + 1)\pi y dA \quad (3.32)$$

$$E_{21}^* = E_{17}^*, \quad E_{22}^* = E_{18}^*, \quad E_{23}^* = E_{19}^*, \quad E_{24}^* = E_{20}^* \quad (3.33)$$

$\Psi_m(x, y)$ is assumed to be the products of functions $\Psi_{pm}(x)\Psi_{bm}(y)$ which are the beam functions in the directions of x and y axes respectively. That is

$$\Psi_m(x, y) = \Psi_{pm}(x)\Psi_{bm}(y) \quad (3.34)$$

where

$$\begin{aligned} \Psi_{pm}(x) &= \sin \lambda_{pm}x + A_{pm} \cos \lambda_{pm}x + B_{pm} \sinh \lambda_{pm}x + C_{pm} \cosh \lambda_{pm}x \\ \Psi_{bm}(y) &= \sin \lambda_{bm}y + A_{bm} \cos \lambda_{bm}y + B_{bm} \sinh \lambda_{bm}y + C_{bm} \cosh \lambda_{bm}y \end{aligned} \quad (3.35)$$

where A_{pm} , B_{pm} , C_{pm} , A_{bm} , B_{bm} and C_{bm} are constants determined by the boundary conditions. And Ψ_{pm} and Ψ_{bm} are called the mode frequencies

where

$$\lambda_{pm} = \frac{\xi_{pm}}{L_x}, \quad \lambda_{bm} = \frac{\xi_{bm}}{L_y} \quad (3.36)$$

Equation (3.10) can be rewritten, if a unit mass is considered as

$$\begin{aligned}
 & \ddot{Q}_n(t) + \omega_n^2 Q_n(t) - \frac{1}{\Delta} \sum_{q=1}^{\infty} \left[R_0 T_0 \ddot{Q}_q(t) - \frac{2B}{\mu} T_1 \dot{Q}_q(t) - \frac{D_x}{\mu} T_2 Q_q(t) - \frac{D_y}{\mu} T_3 Q_q(t) \right. \\
 & + \left(\omega_n^2 - \frac{K_0}{\mu} T_4 \right) Q_q(t) + \frac{G_0}{\mu} T_5 Q_q(t) - \varpi \varphi \left(\left(T_6 + \frac{1}{\pi^2} \left(\sum_{j=1}^{\infty} E_1^* \frac{\cos(2j+1)\pi ct}{2j+1} - \right. \right. \right. \\
 & \left. \left. \sum_{j=1}^{\infty} E_2^* \frac{\sin(2j+1)\pi ct}{2j+1} \right) \left(\sum_{k=1}^{\infty} E_3^* \frac{\cos(2k+1)\pi s}{2k+1} - \sum_{k=1}^{\infty} E_4^* \frac{\sin(2k+1)\pi s}{2k+1} \right) + \frac{1}{4\pi} \left(\sum_{j=1}^{\infty} E_5^* \right. \right. \\
 & \left. \left. \frac{\cos(2j+1)\pi ct}{2j+1} - \sum_{j=1}^{\infty} E_6^* \frac{\sin(2j+1)\pi ct}{2j+1} \right) + \frac{1}{4\pi} \left(\sum_{k=1}^{\infty} E_7^* \frac{\cos(2k+1)\pi s}{2k+1} - \sum_{k=1}^{\infty} E_8^* \right. \right. \\
 & \left. \left. \frac{\sin(2k+1)\pi s}{2k+1} \right) \right) \ddot{Q}_q(t) + 2c \left(T_7 + \frac{1}{\pi^2} \left(\sum_{j=1}^{\infty} E_9^* \frac{\cos(2j+1)\pi ct}{2j+1} - \sum_{j=1}^{\infty} E_{10}^* \frac{\sin(2j+1)\pi ct}{2j+1} \right. \right. \\
 & \left. \left. \right) \left(\sum_{k=1}^{\infty} E_{11}^* \frac{\cos(2k+1)\pi s}{2k+1} - \sum_{j=1}^{\infty} E_{12}^* \frac{\sin(2k+1)\pi s}{2k+1} \right) + \frac{1}{4\pi} \left(\sum_{j=1}^{\infty} E_{13}^* \frac{\cos(2j+1)\pi ct}{2j+1} - \right. \right. \\
 & \left. \left. \sum_{j=1}^{\infty} E_{14}^* \frac{\sin(2j+1)\pi ct}{2j+1} \right) + \frac{1}{4\pi} \left(\sum_{k=1}^{\infty} E_{15}^* \frac{\cos(2k+1)\pi s}{2k+1} - \sum_{k=1}^{\infty} E_{16}^* \frac{\sin(2k+1)\pi s}{2k+1} \right) \right) \dot{Q}_q(t) \\
 & + c^2 \left(T_8 + \frac{1}{\pi^2} \left(\sum_{j=1}^{\infty} E_{17}^* \frac{\cos(2j+1)\pi ct}{2j+1} - \sum_{j=1}^{\infty} E_{18}^* \frac{\sin(2j+1)\pi ct}{2j+1} \right) \left(\sum_{k=1}^{\infty} E_{19}^* \right. \right. \\
 & \left. \left. \frac{\cos(2k+1)\pi s}{2k+1} - \sum_{k=1}^{\infty} E_{20}^* \frac{\sin(2k+1)\pi s}{2k+1} \right) + \frac{1}{4\pi} \left(\sum_{j=1}^{\infty} E_{21}^* \frac{\cos(2j+1)\pi ct}{2j+1} - \sum_{j=1}^{\infty} E_{22}^* \right. \right. \\
 & \left. \left. \frac{\sin(2j+1)\pi ct}{2j+1} \right) + \frac{1}{4\pi} \left(\sum_{k=1}^{\infty} E_{23}^* \frac{\cos(2k+1)\pi s}{2k+1} - \sum_{k=1}^{\infty} E_{24}^* \frac{\sin(2k+1)\pi s}{2k+1} \right) \right) Q_q(t) \Big] \\
 & = \sum_{q=1}^{\infty} \frac{Mg}{\mu\Delta} \Phi_m(ct) \Phi_m(s)
 \end{aligned} \tag{3.37}$$

equation (3.38) is the fundamental equation of the problem. where

$$\varpi = \frac{M}{\mu\varphi}, \quad \varphi = L_x L_y \tag{3.38}$$

$$\Phi_m(ct) = \sin \alpha_m(t) + A_m \cos \alpha_m(t) + B_m \sinh \alpha_m(t) + C_m \cosh \alpha_m(t) \tag{3.39}$$

$$\Phi_m(s) = \sin \lambda_m + A_m \cos \lambda_m + B_m \sinh \lambda_m + C_m \cosh \lambda_m \tag{3.40}$$

$$\alpha_m = \frac{\Gamma_m c}{L_x}, \quad \lambda_m = \frac{\Gamma_m s}{L_y} \tag{3.41}$$

We shall consider the situation where the orthotropic rectangular plate is simply supported at all its edges. The boundary conditions for an orthotropic rectangular plate having simple supports at all its edges are given by

$$W(0, y, t) = 0 = W(L_x, y, t) = 0 \tag{3.42}$$

$$W(x, 0, t) = 0 = W(x, L_y, t) \tag{3.43}$$

$$\frac{\partial^2}{\partial x^2} W(0, y, t) = 0 = \frac{\partial^2}{\partial x^2} W(L_x, y, t) = 0 \tag{3.44}$$

$$\frac{\partial^2}{\partial y^2}W(0, y, t) = 0 = \frac{\partial^2}{\partial y^2}W(x, L_y, t) = 0 \tag{3.45}$$

$$\Phi_m(0) = \Phi_m(L_x) \tag{3.46}$$

$$\Phi_m(0) = \Phi_m(L_y) \tag{3.47}$$

$$\frac{\partial^2}{\partial x^2}\Phi_m(0) = \frac{\partial^2}{\partial x^2}\Phi_m(L_x) \tag{3.48}$$

$$\frac{\partial^2}{\partial y^2}\Phi_m(0) = \frac{\partial^2}{\partial y^2}\Phi_m(L_y) \tag{3.49}$$

$$\Phi_m(x) = \sin \frac{\Gamma_m x}{L_x} + A_m \cos \frac{\Gamma_m x}{L_x} + B_m \sinh \frac{\Gamma_m x}{L_x} + C_m \cosh \frac{\Gamma_m x}{L_x} \tag{3.50}$$

$$\Phi_m(y) = \sin \frac{\Gamma_m y}{L_y} + A_m \cos \frac{\Gamma_m y}{L_y} + B_m \sinh \frac{\Gamma_m y}{L_y} + C_m \cosh \frac{\Gamma_m y}{L_y} \tag{3.51}$$

On putting $x = 0$ and $x = L_x$ into equation (3.51), substituting the answers into equations (3.44) and (3.48). Solving these equations simultaneously, one obtains

$$A_m = 0, \quad B_m = 0, \quad C_m = 0 \tag{3.52}$$

$$\Gamma_m = m\pi \tag{3.53}$$

On putting equations (3.51) to (3.54) into equations (3.11) to (3.34), the integrals become

$$T_0 = - \left[\frac{\pi^2 q^2}{L_x^2} + \frac{\pi^2 q^2}{L_y^2} \right] \int_0^{L_x} \sin \frac{q\pi x}{L_x} \sin \frac{m\pi x}{L_x} dx \int_0^{L_y} \sin \frac{q\pi y}{L_y} \sin \frac{m\pi y}{L_y} dy \tag{3.54}$$

$$T_1 = \frac{\pi^4 q^4}{L_x^2 L_y^2} \int_0^{L_x} \sin \frac{q\pi x}{L_x} \sin \frac{m\pi x}{L_x} dx \int_0^{L_y} \sin \frac{q\pi y}{L_y} \sin \frac{m\pi y}{L_y} dy \tag{3.55}$$

$$T_2 = \frac{\pi^4 q^4}{L_x^4} \int_0^{L_x} \sin \frac{q\pi x}{L_x} \sin \frac{m\pi x}{L_x} dx \int_0^{L_y} \sin \frac{q\pi y}{L_y} \sin \frac{m\pi y}{L_y} dy \tag{3.56}$$

$$T_3 = \frac{\pi^4 q^4}{L_y^4} \int_0^{L_x} \sin \frac{q\pi x}{L_x} \sin \frac{m\pi x}{L_x} dx \int_0^{L_y} \sin \frac{q\pi y}{L_y} \sin \frac{m\pi y}{L_y} dy \tag{3.57}$$

$$T_4 = \int_0^{L_x} \sin \frac{q\pi x}{L_x} \sin \frac{m\pi x}{L_x} dx \int_0^{L_y} \sin \frac{q\pi y}{L_y} \sin \frac{m\pi y}{L_y} dy \tag{3.58}$$

$$T_5 = - \left[\frac{\pi^2 q^2}{L_x^2} + \frac{\pi^2 q^2}{L_y^2} \right] \int_0^{L_x} \sin \frac{q\pi x}{L_x} \sin \frac{m\pi x}{L_x} dx \int_0^{L_y} \sin \frac{q\pi y}{L_y} \sin \frac{m\pi y}{L_y} dy \tag{3.59}$$

$$T_6 = \frac{1}{16} \int_0^{L_x} \sin \frac{q\pi x}{L_x} \sin \frac{m\pi x}{L_x} dx \int_0^{L_y} \sin \frac{q\pi y}{L_y} \sin \frac{m\pi y}{L_y} dy \tag{3.60}$$

$$E_1^* = \int_0^{L_x} \sin \frac{q\pi x}{L_x} \sin \frac{m\pi x}{L_x} \sin(2j+1)\pi x dx \int_0^{L_y} \sin \frac{q\pi y}{L_y} \sin \frac{m\pi y}{L_y} dy \tag{3.61}$$

$$E_2^* = \int_0^{L_x} \sin \frac{q\pi x}{L_x} \sin \frac{m\pi x}{L_x} \cos(2j+1)\pi x dx \int_0^{L_y} \sin \frac{q\pi y}{L_y} \sin \frac{m\pi y}{L_y} dy \tag{3.62}$$

$$E_3^* = \int_0^{L_x} \sin \frac{q\pi x}{L_x} \sin \frac{m\pi x}{L_x} dx \int_0^{L_y} \sin \frac{q\pi y}{L_y} \sin \frac{m\pi y}{L_y} \sin(2k+1)\pi y dy \tag{3.63}$$

$$E_4^* = \int_0^{L_x} \sin \frac{q\pi x}{L_x} \sin \frac{m\pi x}{L_x} dx \int_0^{L_y} \sin \frac{q\pi y}{L_y} \sin \frac{m\pi y}{L_y} \cos(2k+1)\pi y dy \tag{3.64}$$

$$E_5^* = E_1^*, \quad E_6^* = E_2^*, \quad E_7^* = E_3^*, \quad E_8^* = E_4^* \tag{3.65}$$

$$T_7 = \frac{\pi q}{16L_x} \int_0^{L_x} \cos \frac{q\pi x}{L_x} \sin \frac{m\pi x}{L_x} dx \int_0^{L_y} \sin \frac{q\pi y}{L_y} \sin \frac{m\pi y}{L_y} dy \tag{3.66}$$

$$E_9^* = \frac{q\pi}{L_x} \int_0^{L_x} \cos \frac{q\pi x}{L_x} \sin \frac{m\pi x}{L_x} \sin(2j+1)\pi x dx \int_0^{L_y} \sin \frac{q\pi y}{L_y} \sin \frac{m\pi y}{L_y} dy \quad (3.67)$$

$$E_{10}^* = \frac{q\pi}{L_x} \int_0^{L_x} \cos \frac{q\pi x}{L_x} \sin \frac{m\pi x}{L_x} \cos(2j+1)\pi x dx \int_0^{L_y} \sin \frac{q\pi y}{L_y} \sin \frac{m\pi y}{L_y} dy \quad (3.68)$$

$$E_{11}^* = \frac{q\pi}{L_x} \int_0^{L_x} \cos \frac{q\pi x}{L_x} \sin \frac{m\pi x}{L_x} dx \int_0^{L_y} \sin \frac{q\pi y}{L_y} \sin \frac{m\pi y}{L_y} \sin(2k+1)\pi y dy \quad (3.69)$$

$$E_{12}^* = \frac{q\pi}{L_x} \int_0^{L_x} \cos \frac{q\pi x}{L_x} \sin \frac{m\pi x}{L_x} dx \int_0^{L_y} \sin \frac{q\pi y}{L_y} \sin \frac{m\pi y}{L_y} \cos(2k+1)\pi y dy \quad (3.70)$$

$$E_{13}^* = E_9^*, \quad E_{14}^* = E_{10}^*, \quad E_{15}^* = E_{11}^*, \quad E_{16}^* = E_{12}^* \quad (3.71)$$

$$T_8 = -\frac{\pi^2 q^2}{16L_x^2} \int_0^{L_x} \cos \frac{q\pi x}{L_x} \sin \frac{m\pi x}{L_x} dx \int_0^{L_y} \sin \frac{q\pi y}{L_y} \sin \frac{m\pi y}{L_y} dy \quad (3.72)$$

$$E_{17}^* = -\frac{q^2 \pi^2}{L_x^2} \int_0^{L_x} \cos \frac{q\pi x}{L_x} \sin \frac{m\pi x}{L_x} \sin(2j+1)\pi x dx \int_0^{L_y} \sin \frac{q\pi y}{L_y} \sin \frac{m\pi y}{L_y} dy \quad (3.73)$$

$$E_{18}^* = -\frac{q^2 \pi^2}{L_x^2} \int_0^{L_x} \cos \frac{q\pi x}{L_x} \sin \frac{m\pi x}{L_x} \cos(2j+1)\pi x dx \int_0^{L_y} \sin \frac{q\pi y}{L_y} \sin \frac{m\pi y}{L_y} dy \quad (3.74)$$

$$E_{19}^* = \frac{q^2 \pi^2}{L_x^2} \int_0^{L_x} \cos \frac{q\pi x}{L_x} \sin \frac{m\pi x}{L_x} dx \int_0^{L_y} \sin \frac{q\pi y}{L_y} \sin \frac{m\pi y}{L_y} \sin(2k+1)\pi y dy \quad (3.75)$$

$$E_{20}^* = -\frac{q^2 \pi^2}{L_x^2} \int_0^{L_x} \cos \frac{q\pi x}{L_x} \sin \frac{m\pi x}{L_x} dx \int_0^{L_y} \sin \frac{q\pi y}{L_y} \sin \frac{m\pi y}{L_y} \cos(2k+1)\pi y dy \quad (3.76)$$

$$E_{21}^* = E_{17}^* \quad E_{22}^* = E_{18}^* \quad E_{23}^* = E_{19}^* \quad E_{24}^* = E_{20}^* \quad (3.77)$$

On solving equations (3.55) to (3.61),(3.67) and (3.73), and substituting into equation (3.38), one obtains

$$\begin{aligned} \ddot{Q}_n(t) + \omega_n^2 Q_n(t) - \frac{1}{\theta^*} \sum_{q=1}^{\infty} \left[-\frac{R_0 L_x L_y}{4} \left(\frac{\pi^2 q^2}{L_x^2} + \frac{\pi^2 q^2}{L_y^2} \right) \ddot{Q}_q(t) - \frac{2B\pi^4 q^4}{4\mu L_x L_y} Q_q(t) - \right. \\ \left. \frac{D_y \pi^4 q^4 L_x}{4\mu L_y^3} Q_q(t) - \frac{K_0 L_x L_y}{4\mu} Q_q(t) + \frac{G_0 L_x L_y}{4\mu} Q_q(t) - \varpi \varphi \left(\left(\frac{L_x L_y}{64} + \frac{1}{\pi^2} \left(\sum_{j=1}^{\infty} E_1^* \right. \right. \right. \right. \\ \left. \left. \left. \frac{\cos(2j+1)\pi ct}{2j+1} - \sum_{j=1}^{\infty} E_2^* \frac{\sin(2j+1)\pi ct}{2j+1} \right) \left(\sum_{k=1}^{\infty} E_3^* \frac{\cos(2k+1)\pi s}{2k+1} - \sum_{k=1}^{\infty} E_4^* \frac{\sin(2k+1)\pi s}{2k+1} \right. \right. \right. \\ \left. \left. \left. \right) + \frac{1}{4\pi} \left(\sum_{j=1}^{\infty} E_5^* \frac{\cos(2j+1)\pi ct}{2j+1} - \sum_{j=1}^{\infty} E_6^* \frac{\sin(2j+1)\pi ct}{2j+1} \right) + \frac{1}{4\pi} \left(\sum_{k=1}^{\infty} E_7^* \frac{\cos(2k+1)\pi s}{2k+1} \right. \right. \\ \left. \left. - \sum_{k=1}^{\infty} E_8^* \frac{\sin(2k+1)\pi s}{2k+1} \right) \right] \ddot{Q}_q(t) + 2ct \left(\frac{-4mL_x}{64(q^2 - m^2)\pi} + \frac{1}{\pi^2} \left(\sum_{j=1}^{\infty} E_9^* \frac{\cos(2j+1)\pi ct}{2j+1} \right. \right. \\ \left. \left. - \sum_{j=1}^{\infty} E_{10}^* \frac{\sin(2j+1)\pi ct}{2j+1} \right) \left(\sum_{k=1}^{\infty} E_{11}^* \frac{\cos(2k+1)\pi s}{2k+1} - \sum_{k=1}^{\infty} E_{12}^* \frac{\sin(2k+1)\pi s}{2k+1} \right) \right) \end{aligned}$$

$$\begin{aligned}
 & + \frac{1}{4\pi} \left(\sum_{j=1}^{\infty} E_{13}^* \frac{\cos(2j+1)\pi ct}{2j+1} - \sum_{j=1}^{\infty} E_{14}^* \frac{\sin(2j+1)\pi ct}{2j+1} \right) + \frac{1}{4\pi} \left(\sum_{k=1}^{\infty} E_{15}^* \frac{\cos(2k+1)\pi s}{2k+1} \right. \\
 & \left. - \sum_{k=1}^{\infty} E_{16}^* \frac{\sin(2k+1)\pi s}{2k+1} \right) \dot{Q}_q(t) + c^2 \left(\frac{-\pi^2 q^2 L_y}{64L_x} + \frac{1}{\pi^2} \left(\sum_{j=1}^{\infty} E_{17}^* \frac{\cos(2j+1)\pi ct}{2j+1} - \right. \right. \\
 & \left. \sum_{j=1}^{\infty} E_{18}^* \frac{\sin(2j+1)\pi ct}{2j+1} \right) \left(\sum_{k=1}^{\infty} E_{19}^* \frac{\cos(2k+1)\pi s}{2k+1} - \sum_{k=1}^{\infty} E_{20}^* \frac{\sin(2k+1)\pi s}{2k+1} \right) + \frac{1}{4\pi} \quad (3.78) \\
 & \left(\sum_{j=1}^{\infty} E_{21}^* \frac{\cos(2j+1)\pi ct}{2j+1} - \sum_{j=1}^{\infty} E_{22}^* \frac{\sin(2j+1)\pi ct}{2j+1} \right) + \frac{1}{4\pi} \left(\sum_{k=1}^{\infty} E_{23}^* \frac{\cos(2k+1)\pi s}{2k+1} - \right. \\
 & \left. \sum_{k=1}^{\infty} E_{24}^* \frac{\sin(2k+1)\pi s}{2k+1} \right) \left. \right) Q_q(t) \Big] = \sum_{q=1}^{\infty} \frac{Mg}{\mu\Delta} \Phi_m(ct) \Phi_m(s)
 \end{aligned}$$

The solutions to equation (3.79) shall be obtained by considering two cases:

3.1 Simply Supported Orthotropic Rectangular Plate Transversed by Moving Force.

For moving force problem, one sets $\varpi = 0$ in equation (3.79) which becomes

$$\begin{aligned}
 & \ddot{Q}_n(t) + \omega_n^2 Q_n(t) - \frac{1}{\mu\theta^*} \left[-\frac{\mu R_0 L_x L_y}{4} \left(\frac{\pi^2 n^2}{L_x^2} + \frac{\pi^2 n^2}{L_y^2} \right) \ddot{Q}_n(t) - \frac{2B\pi^4 n^4}{4L_x L_y} Q_n(t) - \right. \\
 & \frac{D_x \pi^4 n^4 L_y}{4L_x^3} Q_n(t) - \frac{D_y \pi^4 n^4 L_x}{4L_y^3} Q_n(t) + \left(\omega_n^2 - \frac{K_0 L_x L_y}{4} \right) Q_n(t) + \frac{G_0 L_x L_y}{4} \left(\frac{\pi^2 n^2}{L_x^2} \right. \\
 & \left. + \frac{\pi^2 n^2}{L_y^2} \right) Q_n(t) + \sum_{q=1, q \neq n}^{\infty} \left(-\frac{\mu R_0 L_x L_y}{4} \left(\frac{\pi^2 q^2}{L_x^2} + \frac{\pi^2 q^2}{L_y^2} \right) \ddot{Q}_q(t) - \frac{2B\pi^4 q^4}{4L_x L_y} Q_q(t) - \right. \quad (3.79) \\
 & \left. \frac{D_x \pi^4 q^4 L_y}{4L_x^3} - \frac{D_y \pi^4 q^4 L_x}{4L_y^3} Q_q(t) - \frac{K_0 L_x L_y}{4} Q_q(t) - \frac{G_0 L_x L_y}{4} \left(\frac{\pi^2 q^2}{L_x^2} + \frac{\pi^2 q^2}{L_y^2} \right) Q_q(t) \right] \\
 & = \sum_{q=1}^{\infty} \frac{Mg}{\mu\Delta} \sin \frac{m\pi s}{L_y} \sin \frac{m\pi ct}{L_x}
 \end{aligned}$$

On further simplification and re-arrangement, one obtains

$$\begin{aligned}
 & \left[1 + \eta \frac{\mu R_0 L_x L_y}{4} \left(\frac{\pi^2 n^2}{L_x^2} + \frac{\pi^2 n^2}{L_y^2} \right) \right] \ddot{Q}_n(t) + \left(\omega_n^2 - \eta \left(-\frac{2B\pi^4 n^4}{4L_x L_y} - \frac{D_x \pi^4 n^4 L_y}{4L_x^3} - \right. \right. \\
 & \left. \frac{D_y \pi^4 n^4 L_x}{4L_y^3} + \left(\mu\omega_n^2 - \frac{K_0 L_x L_y}{4} \right) + \frac{G_0 L_x L_y}{4} \left(\frac{\pi^2 n^2}{L_x^2} + \frac{\pi^2 n^2}{L_y^2} \right) \right) Q_n(t) + \sum_{q=1, q \neq n}^{\infty} \left(\right. \\
 & \left. - \frac{\mu R_0 L_x L_y}{4} \left(\frac{\pi^2 q^2}{L_x^2} + \frac{\pi^2 q^2}{L_y^2} \right) \ddot{Q}_q(t) - \frac{2B\pi^4 q^4}{4L_x L_y} Q_q(t) - \frac{D_x \pi^4 q^4 L_y}{4L_x^3} Q_q(t) - \frac{D_y \pi^4 q^4 L_x}{4L_y^3} Q_q(t) \right. \\
 & \left. - \frac{K_0 L_x L_y}{4} Q_q(t) + \frac{G_0 L_x L_y}{4} \left(\frac{\pi^2 q^2}{L_x^2} + \frac{\pi^2 q^2}{L_y^2} \right) Q_q(t) \right) = \sum_{q=1}^{\infty} Mg\eta \sin \frac{m\pi s}{L_y} \sin \frac{m\pi ct}{L_x} \quad (3.80)
 \end{aligned}$$

where

$$\eta = \frac{1}{\mu\theta^*} \quad (3.81)$$

Consider a parameter $\eta^* < 1$ for any arbitrary mass ratio η , defined as

$$\eta = \frac{\eta^*}{1 + \eta^*} \tag{3.82}$$

It can be shown that

$$\eta = \eta^* - o(\eta^{*2}) \tag{3.83}$$

Retaining only $o(\eta^*)$, one obtains

$$\eta = \eta^* \tag{3.84}$$

On putting equation (3.85) into equation (3.81) and rewriting it, one obtains

$$\begin{aligned} \ddot{Q}_n(t) + \frac{1}{1 + \eta^* \frac{\mu R_0 L_x L_y}{4} \left(\frac{\pi^2 n^2}{L_x^2} + \frac{\pi^2 n^2}{L_y^2} \right)} & \left(\omega_n^2 - \eta^* \left(-\frac{2B\pi^4 n^4}{4L_x L_y} - \frac{D_x \pi^4 n^4 L_y}{4L_x^3} - \frac{D_y \pi^4 n^4 L_x}{4L_y^3} + \left(\mu \omega_n^2 \right. \right. \right. \\ & \left. \left. - \frac{K_0 L_x L_y}{4} \right) + \frac{G_0 L_x L_y}{4} \left(\frac{\pi^2 n^2}{L_x^2} + \frac{\pi^2 n^2}{L_y^2} \right) \right) Q_n(t) + \frac{\eta^*}{1 + \eta^* \frac{\mu R_0 L_x L_y}{4} \left(\frac{\pi^2 n^2}{L_x^2} + \frac{\pi^2 n^2}{L_y^2} \right)} \sum_{q=1, q \neq n}^{\infty} \\ & \left(-\frac{\mu R_0 L_x L_y}{4} \left(\frac{\pi^2 q^2}{L_x^2} + \frac{\pi^2 q^2}{L_y^2} \right) \ddot{Q}_q(t) - \left(\frac{2B\pi^4 q^4}{4L_x L_y} + \frac{D_x \pi^4 q^4 L_y}{4L_x^3} + \frac{D_y \pi^4 q^4 L_x}{4L_y^3} + \frac{K_0 L_x L_y}{4} \right. \right. \\ & \left. \left. - \frac{G_0 L_x L_y}{4} \left(\frac{\pi^2 q^2}{L_x^2} + \frac{\pi^2 q^2}{L_y^2} \right) \right) Q_q(t) \right) = \frac{Mg\eta^* \sin \frac{m\pi s}{L_y} \sin \frac{m\pi ct}{L_x}}{1 + \eta^* \frac{\mu R_0 L_x L_y}{4} \left(\frac{\pi^2 n^2}{L_x^2} + \frac{\pi^2 n^2}{L_y^2} \right)} \end{aligned} \tag{3.85}$$

Applying binomial expansion, one obtains

$$\frac{1}{1 + \eta^* \frac{\mu R_0 L_x L_y}{4} \left(\frac{\pi^2 n^2}{L_x^2} + \frac{\pi^2 n^2}{L_y^2} \right)} = 1 - \eta^* \frac{\mu R_0 L_x L_y}{4} \left(\frac{\pi^2 n^2}{L_x^2} + \frac{\pi^2 n^2}{L_y^2} \right) + o(\eta^{*2}) + \dots \tag{3.86}$$

On substituting equation (3.87) into equation (3.86), one obtains

$$\begin{aligned} \ddot{Q}_n(t) + \left[\omega_n^2 \left(1 - \eta^* \frac{\mu R_0 L_x L_y}{4} \left(\frac{\pi^2 n^2}{L_x^2} + \frac{\pi^2 n^2}{L_y^2} \right) + o(\eta^{*2}) + \dots \right) - \eta^* \left(\frac{2B\pi^4 n^4}{4L_x L_y} - \frac{D_x \pi^4 n^4 L_y}{4L_x^3} \right. \right. \\ & \left. \left. - \frac{D_y \pi^4 n^4 L_x}{4L_y^3} + \left(\mu \omega_n^2 - \frac{K_0 L_x L_y}{4} \right) + \frac{G_0 L_x L_y}{4} \left(\frac{\pi^2 n^2}{L_x^2} + \frac{\pi^2 n^2}{L_y^2} \right) \right) \left(1 - \eta^* \frac{\mu R_0 L_x L_y}{4} \left(\frac{\pi^2 n^2}{L_x^2} \right. \right. \right. \\ & \left. \left. + \frac{\pi^2 n^2}{L_y^2} \right) + o(\eta^{*2}) + \dots \right] Q_n(t) - \eta^* \left(1 - \eta^* \frac{\mu R_0 L_x L_y}{4} \left(\frac{\pi^2 n^2}{L_x^2} + \frac{\pi^2 n^2}{L_y^2} \right) + o(\eta^{*2}) + \dots \right) \\ & \sum_{q=1, q \neq n}^{\infty} \left(-\frac{\mu R_0 L_x L_y}{4} \left(\frac{\pi^2 q^2}{L_x^2} + \frac{\pi^2 q^2}{L_y^2} \right) \ddot{Q}_q(t) - \left(\frac{2B\pi^4 q^4}{4L_x L_y} + \frac{D_x \pi^4 q^4 L_y}{4L_x^3} + \frac{D_y \pi^4 q^4 L_x}{4L_y^3} + \right. \right. \\ & \left. \left. \frac{K_0 L_x L_y}{4} - \frac{G_0 L_x L_y}{4} \left(\frac{\pi^2 q^2}{L_x^2} + \frac{\pi^2 q^2}{L_y^2} \right) \right) Q_q(t) \right) = Mg\eta^* \sin \frac{m\pi s}{L_y} \sin \frac{m\pi ct}{L_x} \end{aligned} \tag{3.87}$$

Expanding equation (3.88), and retaining only $o(\eta^*)$, one obtains

$$\begin{aligned} \ddot{Q}_n(t) + \left[\omega_n^2 \left(1 - \eta^* \frac{\mu R_0 L_x L_y}{4} \left(\frac{\pi^2 n^2}{L_x^2} + \frac{\pi^2 n^2}{L_y^2} \right) \right) - \eta^* \left(\frac{2B\pi^4 n^4}{4L_x L_y} - \frac{D_x \pi^4 n^4 L_y}{4L_x^3} - \frac{D_y \pi^4 n^4 L_x}{4L_y^3} \right. \right. \\ \left. \left. + \left(\mu \omega_n^2 - \frac{K_0 L_x L_y}{4} \right) + \frac{G_0 L_x L_y}{4} \left(\frac{\pi^2 n^2}{L_x^2} + \frac{\pi^2 n^2}{L_y^2} \right) \right] Q_n(t) - \eta^* \left(1 - \eta^* \frac{\mu R_0 L_x L_y}{4} \left(\frac{\pi^2 n^2}{L_x^2} \right. \right. \\ \left. \left. + \frac{\pi^2 n^2}{L_y^2} \right) \right) \sum_{q=1, q \neq n}^{\infty} \left(-\frac{\mu R_0 L_x L_y}{4} \left(\frac{\pi^2 q^2}{L_x^2} + \frac{\pi^2 q^2}{L_y^2} \right) \ddot{Q}_q(t) - \left(\frac{2B\pi^4 q^4}{4L_x L_y} + \frac{D_x \pi^4 q^4 L_y}{4L_x^3} + \right. \right. \\ \left. \left. \frac{D_y \pi^4 q^4 L_x}{4L_y^3} + \frac{K_0 L_x L_y}{4} - \frac{G_0 L_x L_y}{4} \left(\frac{\pi^2 q^2}{L_x^2} + \frac{\pi^2 q^2}{L_y^2} \right) \right) \right) Q_q(t) = Mg\eta^* \sin \frac{m\pi s}{L_y} \sin \frac{m\pi ct}{L_x} \end{aligned} \quad (3.88)$$

Using Struble's technique, the solution to equation (3.89) takes the form

$$Q_n(t) = A(n, t) \cos(\omega_n t - B(n, t)) + \dots \quad (3.89)$$

$$\begin{aligned} Q_n(t) = E_n \cos \left[\omega_n t - \frac{\eta^*}{2\omega_n^2} \left(\frac{G_0 L_x L_y}{4} \left(\frac{\pi^2 n^2}{L_x^2} + \frac{\pi^2 n^2}{L_y^2} \right) - \frac{B\pi^4 n^4}{4L_x L_y} - \frac{D_x \pi^4 n^4 L_y}{4L_x^3} \right. \right. \\ \left. \left. - \frac{D_y \pi^4 n^4 L_x}{4L_y^3} + \left(\mu \omega_n^2 - \frac{K_0 L_x L_y}{4} \right) + \frac{R_0 L_x L_y}{4} \left(\frac{\pi^2 n^2}{L_x^2} + \frac{\pi^2 n^2}{L_y^2} \right) \right) t - \Psi_n \right] \end{aligned} \quad (3.90)$$

On further simplifications, one obtains

$$Q_n(t) = E_n \cos(\Gamma_n t - \Psi_n) \quad (3.91)$$

where

$$\begin{aligned} \Gamma_n = \omega_n - \frac{\eta^*}{2\omega_n^2} \left[\frac{G_0 L_x L_y}{4} \left(\frac{\pi^2 n^2}{L_x^2} + \frac{\pi^2 n^2}{L_y^2} \right) - \frac{B\pi^4 n^4}{4L_x L_y} - \frac{D_x \pi^4 n^4 L_y}{4L_x^3} \right. \\ \left. - \frac{D_y \pi^4 n^4 L_x}{4L_y^3} + \left(\mu \omega_n^2 - \frac{K_0 L_x L_y}{4} \right) + \frac{R_0 L_x L_y}{4} \left(\frac{\pi^2 n^2}{L_x^2} + \frac{\pi^2 n^2}{L_y^2} \right) \right] \end{aligned} \quad (3.92)$$

is the modified frequency for simply supported orthotropic rectangular plate traversed by moving force.

The homogeneous part of equation (3.89) gives

$$\ddot{Q}_n(t) + \Gamma_n^2 Q_n(t) = 0 \quad (3.93)$$

Hence, the entire equation (3.89) becomes

$$\ddot{Q}_n(t) + \Gamma_n^2 Q_n(t) = Mg\eta^* \sin \frac{m\pi s}{L_y} \sin \frac{m\pi ct}{L_x} \quad (3.94)$$

when equation (3.95) is solved in conjunction with the initial conditions (2.4), one obtains

$$Q_n(t) = \frac{Mg\eta^*}{\Gamma_n} \sin \frac{m\pi s}{L_y} \times \left[\frac{\Gamma_n \sin \frac{m\pi c t}{L_x} - \left(\frac{m\pi c}{L_x} \right) \sin \Gamma_n t}{\left(\frac{m\pi c}{L_x} \right)^2 - \Gamma_n^2} \right] \quad (3.95)$$

Thus, in view of equation (3.1), one obtains

$$W(x, y, t) = \frac{Mg\eta^*}{\Gamma_n} \sin \frac{m\pi s}{L_y} \times \left[\frac{\Gamma_n \sin \frac{m\pi c t}{L_x} - \left(\frac{m\pi c}{L_x} \right) \sin \Gamma_n t}{\left(\frac{m\pi c}{L_x} \right)^2 - \Gamma_n^2} \right] \times \sin \frac{m\pi x}{L_x} \sin \frac{m\pi y}{L_y} \quad (3.96)$$

is the transverse displacement response to a moving force of a simply supported orthotropic rectangular plate.

3.2 Simply Supported Orthotropic Rectangular Plate Transversed by Moving Mass

Here, one seeks solution to the entire equation (3.79). To solve this problem, one makes use of the modified asymptotic Struble technique. The equation becomes,

$$\begin{aligned}
 & \ddot{Q}_n(t) + \Gamma_n^2 Q_n(t) + \varpi\varphi \sum_{q=1}^{\infty} \left[\left(\frac{L_x L_y}{64} + \frac{1}{\pi^2} \left(\sum_{j=1}^{\infty} E_1^* \frac{\cos(2j+1)\pi ct}{2j+1} - \sum_{j=1}^{\infty} E_2^* \right. \right. \right. \\
 & \left. \left. \frac{\sin(2j+1)\pi ct}{2j+1} \right) \left(\sum_{k=1}^{\infty} E_3^* \frac{\cos(2k+1)\pi s}{2k+1} - \sum_{k=1}^{\infty} E_4^* \frac{\sin(2k+1)\pi s}{2k+1} \right) + \frac{1}{4\pi} \left(\sum_{j=1}^{\infty} E_5^* \right. \right. \\
 & \left. \left. \frac{\cos(2j+1)\pi ct}{2j+1} - \sum_{j=1}^{\infty} E_6^* \frac{\sin(2j+1)\pi ct}{2j+1} \right) + \frac{1}{4\pi} \left(\sum_{k=1}^{\infty} E_7^* \frac{\cos(2k+1)\pi s}{2k+1} - \sum_{k=1}^{\infty} E_8^* \right. \right. \\
 & \left. \left. \frac{\sin(2k+1)\pi s}{2k+1} \right) \right) \ddot{Q}_q(t) + 2c \left(\frac{-4mL_y}{64(q^2 - m^2)\pi} + \frac{1}{\pi^2} \left(\sum_{j=1}^{\infty} E_9^* \frac{\cos(2j+1)\pi ct}{2j+1} - \sum_{j=1}^{\infty} E_{10}^* \right. \right. \\
 & \left. \left. \frac{\sin(2j+1)\pi ct}{2j+1} \right) \left(\sum_{k=1}^{\infty} E_{11}^* \frac{\cos(2k+1)\pi s}{2k+1} - \sum_{k=1}^{\infty} E_{12}^* \frac{\sin(2k+1)\pi s}{2k+1} \right) + \frac{1}{4\pi} \left(\sum_{j=1}^{\infty} E_{13}^* \right. \right. \\
 & \left. \left. \frac{\cos(2j+1)\pi ct}{2j+1} - \sum_{j=1}^{\infty} E_{14}^* \frac{\sin(2j+1)\pi ct}{2j+1} \right) + \frac{1}{4\pi} \left(\sum_{k=1}^{\infty} E_{15}^* \frac{\cos(2k+1)\pi s}{2k+1} - \sum_{k=1}^{\infty} E_{16}^* \right. \right. \\
 & \left. \left. \frac{\sin(2k+1)\pi s}{2k+1} \right) \right) \dot{Q}_q(t) + c^2 \left(\frac{-\pi^2 q^2 L_y}{64L_x} + \frac{1}{\pi^2} \left(\sum_{j=1}^{\infty} E_{17}^* \frac{\cos(2j+1)\pi ct}{2j+1} - \sum_{j=1}^{\infty} E_{18}^* \right. \right. \\
 & \left. \left. \frac{\sin(2j+1)\pi ct}{2j+1} \right) \left(\sum_{k=1}^{\infty} E_{19}^* \frac{\cos(2k+1)\pi s}{2k+1} - \sum_{k=1}^{\infty} E_{20}^* \frac{\sin(2k+1)\pi s}{2k+1} \right) + \frac{1}{4\pi} \left(\sum_{j=1}^{\infty} E_{21}^* \right. \right. \\
 & \left. \left. - \sum_{j=1}^{\infty} E_{22}^* \frac{\sin(2j+1)\pi ct}{2j+1} \right) + \frac{1}{4\pi} \left(\sum_{k=1}^{\infty} E_{23}^* \frac{\cos(2k+1)\pi s}{2k+1} - \sum_{k=1}^{\infty} E_{24}^* \frac{\sin(2k+1)\pi s}{2k+1} \right. \right. \\
 & \left. \left. \right) \right) Q_q(t) = \varpi\varphi \frac{m\pi s}{L_y} \sin \frac{m\pi ct}{L_x}
 \end{aligned} \tag{3.97}$$

On further simplifications, equation (3.98) one obtains

$$\begin{aligned}
 & \left(1 + \varpi\varphi\delta(i, j) \right) \ddot{Q}_n(t) + 2c\varpi\varphi \left(\frac{-4mL_y}{64(n^2 - m^2)\pi} + \frac{1}{\pi^2} \left(\sum_{j=1}^{\infty} E_9^* \frac{\cos(2j+1)\pi ct}{2j+1} - \right. \right. \\
 & \left. \left. \sum_{j=1}^{\infty} E_{10}^* \frac{\sin(2j+1)\pi ct}{2j+1} \right) \left(\sum_{k=1}^{\infty} E_{11}^* \frac{\cos(2k+1)\pi s}{2k+1} - \sum_{k=1}^{\infty} E_{12}^* \frac{\sin(2k+1)\pi s}{2k+1} \right) \right. \\
 & \left. + \frac{1}{4\pi} \left(\sum_{j=1}^{\infty} E_{13}^* \frac{\cos(2j+1)\pi ct}{2j+1} - \sum_{j=1}^{\infty} E_{14}^* \frac{\sin(2j+1)\pi ct}{2j+1} \right) + \frac{1}{4\pi} \left(\sum_{k=1}^{\infty} E_{15}^* \right. \right. \\
 & \left. \left. \frac{\cos(2k+1)\pi s}{2k+1} - \sum_{k=1}^{\infty} E_{16}^* \frac{\sin(2k+1)\pi s}{2k+1} \right) \right) \dot{Q}_n(t) + \left[\Gamma_n^2 + c^2 \left(\frac{-\pi^2 q^2 L_y}{64L_x} + \frac{1}{\pi^2} \right. \right. \\
 & \left. \left. \left(\sum_{j=1}^{\infty} E_{17}^* \frac{\cos(2j+1)\pi ct}{2j+1} - \sum_{j=1}^{\infty} E_{18}^* \frac{\sin(2j+1)\pi ct}{2j+1} \right) \left(\sum_{k=1}^{\infty} E_{19}^* \frac{\cos(2k+1)\pi s}{2k+1} - \right. \right. \right.
 \end{aligned}$$

$$\begin{aligned}
 & \sum_{k=1}^{\infty} E_{20}^* \frac{\sin(2k+1)\pi s}{2k+1} \Bigg) + \frac{1}{4\pi} \left(\sum_{j=1}^{\infty} E_{21}^* \frac{\cos(2j+1)\pi ct}{2j+1} - \sum_{j=1}^{\infty} E_{22}^* \frac{\sin(2j+1)\pi ct}{2j+1} \right) \\
 & + \frac{1}{4\pi} \left(\sum_{k=1}^{\infty} E_{23}^* \frac{\cos(2k+1)\pi s}{2k+1} - \sum_{k=1}^{\infty} E_{24}^* \frac{\sin(2k+1)\pi s}{2k+1} \right) \Bigg] Q_n(t) + \varpi\varphi \sum_{q=1, q \neq n}^{\infty} \\
 & \left[\left(\frac{L_x L_y}{64} + \frac{1}{\pi^2} \left(\sum_{j=1}^{\infty} E_1^* \frac{\cos(2j+1)\pi ct}{2j+1} - \sum_{j=1}^{\infty} E_2^* \frac{\sin(2j+1)\pi ct}{2j+1} \right) \right) \left(\sum_{k=1}^{\infty} E_3^* \frac{\cos(2k+1)\pi s}{2k+1} \right. \right. \\
 & - \sum_{k=1}^{\infty} E_4^* \frac{\sin(2k+1)\pi s}{2k+1} \Bigg) + \frac{1}{4\pi} \left(\sum_{j=1}^{\infty} E_5^* \frac{\cos(2j+1)\pi ct}{2j+1} - \sum_{j=1}^{\infty} E_6^* \frac{\sin(2j+1)\pi ct}{2j+1} \right) \\
 & + \frac{1}{4\pi} \left(\sum_{k=1}^{\infty} E_7^* \frac{\cos(2k+1)\pi s}{2k+1} - \sum_{k=1}^{\infty} E_8^* \frac{\sin(2k+1)\pi s}{2k+1} \right) \Bigg] \ddot{Q}_q(t) + 2c \left(\frac{-4mL_y}{64(q^2 - m^2)\pi} \right. \\
 & + \frac{1}{\pi^2} \left(\sum_{j=1}^{\infty} E_9^* \frac{\cos(2j+1)\pi ct}{2j+1} - \sum_{j=1}^{\infty} E_{10}^* \frac{\sin(2j+1)\pi ct}{2j+1} \right) \left(\sum_{k=1}^{\infty} E_{11}^* \frac{\cos(2k+1)\pi s}{2k+1} \right. \\
 & - \sum_{k=1}^{\infty} E_{12}^* \frac{\sin(2k+1)\pi s}{2k+1} \Bigg) + \frac{1}{4\pi} \left(\sum_{j=1}^{\infty} E_{13}^* \frac{\cos(2j+1)\pi ct}{2j+1} - \sum_{j=1}^{\infty} E_{14}^* \frac{\sin(2j+1)\pi ct}{2j+1} \right) \\
 & + \frac{1}{4\pi} \left(\sum_{k=1}^{\infty} E_{15}^* \frac{\cos(2k+1)\pi s}{2k+1} - \sum_{k=1}^{\infty} E_{16}^* \frac{\sin(2k+1)\pi s}{2k+1} \right) \Bigg] \dot{Q}_q(t) + c^2 \left(\frac{-\pi^2 q^2 L_y}{64L_x} \right. \\
 & + \frac{1}{\pi^2} \left(\sum_{j=1}^{\infty} E_{17}^* \frac{\cos(2j+1)\pi ct}{2j+1} - \sum_{j=1}^{\infty} E_{18}^* \frac{\sin(2j+1)\pi ct}{2j+1} \right) \left(\sum_{k=1}^{\infty} E_{19}^* \frac{\cos(2k+1)\pi s}{2k+1} \right. \\
 & - \sum_{k=1}^{\infty} E_{20}^* \frac{\sin(2k+1)\pi s}{2k+1} \Bigg) + \frac{1}{4\pi} \left(\sum_{j=1}^{\infty} E_{21}^* \frac{\cos(2j+1)\pi ct}{2j+1} - \sum_{j=1}^{\infty} E_{22}^* \frac{\sin(2j+1)\pi ct}{2j+1} \right) \\
 & + \frac{1}{4\pi} \left(\sum_{k=1}^{\infty} E_{23}^* \frac{\cos(2k+1)\pi s}{2k+1} - \sum_{k=1}^{\infty} E_{24}^* \frac{\sin(2k+1)\pi s}{2k+1} \right) \Bigg] Q_q(t) = \varpi\varphi \sin \frac{m\pi s}{L_y} \\
 & \sin \frac{m\pi ct}{L_x}
 \end{aligned} \tag{3.98}$$

where

$$\begin{aligned}
 \delta(i, j) = & \left(\frac{L_x L_y}{64} + \frac{1}{\pi^2} \left(\sum_{j=1}^{\infty} E_1^* \frac{\cos(2j+1)\pi ct}{2j+1} - \sum_{j=1}^{\infty} E_2^* \frac{\sin(2j+1)\pi ct}{2j+1} \right) \right) \left(\sum_{k=1}^{\infty} E_3^* \right. \\
 & \left. \frac{\cos(2k+1)\pi s}{2k+1} - \sum_{k=1}^{\infty} E_4^* \frac{\sin(2k+1)\pi s}{2k+1} \right) + \frac{1}{4\pi} \left(\sum_{j=1}^{\infty} E_5^* \frac{\cos(2j+1)\pi ct}{2j+1} - \sum_{j=1}^{\infty} E_6^* \right. \\
 & \left. \frac{\sin(2j+1)\pi ct}{2j+1} \right) + \frac{1}{4\pi} \left(\sum_{k=1}^{\infty} E_7^* \frac{\cos(2k+1)\pi s}{2k+1} - \sum_{k=1}^{\infty} E_8^* \frac{\sin(2k+1)\pi s}{2k+1} \right) \Bigg)
 \end{aligned} \tag{3.99}$$

Rewriting equation (3.99), one obtains

$$\begin{aligned}
 \ddot{Q}_n(t) + \frac{2c\varpi\varphi}{\left(1 + \varpi\varphi\delta(i, j)\right)} & \left(\frac{-4mL_y}{64(q^2 - m^2)\pi} + \frac{1}{\pi^2} \left(\sum_{j=1}^{\infty} E_9^* \frac{\cos(2j+1)\pi ct}{2j+1} - \sum_{j=1}^{\infty} E_{10}^* \right. \right. \\
 & \left. \left. \frac{\sin(2j+1)\pi ct}{2j+1} \right) \right) \left(\sum_{k=1}^{\infty} E_{11}^* \frac{\cos(2k+1)\pi s}{2k+1} - \sum_{k=1}^{\infty} E_{12}^* \frac{\sin(2k+1)\pi s}{2k+1} \right) + \frac{1}{4\pi} \left(\sum_{j=1}^{\infty} E_{13}^* \right.
 \end{aligned}$$

$$\begin{aligned}
 & \left. \left. \left. \frac{\cos(2j+1)\pi ct}{2j+1} - \sum_{j=1}^{\infty} E_{14}^* \frac{\sin(2j+1)\pi ct}{2j+1} \right) + \frac{1}{4\pi} \left(\sum_{k=1}^{\infty} E_{15}^* \frac{\cos(2k+1)\pi s}{2k+1} - \sum_{k=1}^{\infty} E_{16}^* \frac{\sin(2k+1)\pi s}{2k+1} \right) \right) \dot{Q}_n(t) + \frac{1}{\left(1 + \varpi\varphi\delta(i, j)\right)} \left[\Gamma_n^2 + c^2 \left(\frac{-\pi^2 q^2 L_y}{64L_x} + \frac{1}{\pi^2} \left(\sum_{j=1}^{\infty} E_{17}^* \frac{\cos(2j+1)\pi ct}{2j+1} - \sum_{j=1}^{\infty} E_{18}^* \frac{\sin(2j+1)\pi ct}{2j+1} \right) \right. \right. \\
 & \left. \left. \left. \frac{\cos(2j+1)\pi ct}{2j+1} - \sum_{j=1}^{\infty} E_{18}^* \frac{\sin(2j+1)\pi ct}{2j+1} \right) \left(\sum_{k=1}^{\infty} E_{19}^* \frac{\cos(2k+1)\pi s}{2k+1} - \sum_{k=1}^{\infty} E_{20}^* \frac{\sin(2k+1)\pi s}{2k+1} \right) + \frac{1}{4\pi} \left(\sum_{j=1}^{\infty} E_{21}^* \frac{\cos(2j+1)\pi ct}{2j+1} - \sum_{j=1}^{\infty} E_{22}^* \frac{\sin(2j+1)\pi ct}{2j+1} \right) + \frac{1}{4\pi} \right. \\
 & \left. \left. \left. \left(\sum_{k=1}^{\infty} E_{23}^* \frac{\cos(2k+1)\pi s}{2k+1} - \sum_{k=1}^{\infty} E_{24}^* \frac{\sin(2k+1)\pi s}{2k+1} \right) \right) \right] Q_n(t) + \frac{\varpi\varphi}{\left(1 + \varpi\varphi\delta(i, j)\right)} \\
 & \sum_{q=1, q \neq n}^{\infty} \left[\left(\frac{L_x L_y}{64} + \frac{1}{\pi^2} \left(\sum_{j=1}^{\infty} E_1^* \frac{\cos(2j+1)\pi ct}{2j+1} - \sum_{j=1}^{\infty} E_2^* \frac{\sin(2j+1)\pi ct}{2j+1} \right) \left(\sum_{k=1}^{\infty} E_3^* \frac{\cos(2k+1)\pi s}{2k+1} - \sum_{k=1}^{\infty} E_4^* \frac{\sin(2k+1)\pi s}{2k+1} \right) + \frac{1}{4\pi} \left(\sum_{j=1}^{\infty} E_5^* \frac{\cos(2j+1)\pi ct}{2j+1} - \sum_{j=1}^{\infty} E_6^* \frac{\sin(2j+1)\pi ct}{2j+1} \right) \right. \\
 & \left. \left. \left. \frac{\sin(2j+1)\pi ct}{2j+1} \right) + \frac{1}{4\pi} \left(\sum_{k=1}^{\infty} E_7^* \frac{\cos(2k+1)\pi s}{2k+1} - \sum_{k=1}^{\infty} E_8^* \frac{\sin(2k+1)\pi s}{2k+1} \right) \right) \dot{Q}_q(t) \right. \\
 & \left. + 2c \left(\frac{-4mL_y}{64(q^2 - m^2)\pi} + \frac{1}{\pi^2} \left(\sum_{j=1}^{\infty} E_9^* \frac{\cos(2j+1)\pi ct}{2j+1} - \sum_{j=1}^{\infty} E_{10}^* \frac{\sin(2j+1)\pi ct}{2j+1} \right) \right. \right. \\
 & \left. \left. \left. \left(\sum_{k=1}^{\infty} E_{11}^* \frac{\cos(2k+1)\pi s}{2k+1} - \sum_{k=1}^{\infty} E_{12}^* \frac{\sin(2k+1)\pi s}{2k+1} \right) + \frac{1}{4\pi} \left(\sum_{j=1}^{\infty} E_{13}^* \frac{\cos(2j+1)\pi ct}{2j+1} - \sum_{j=1}^{\infty} E_{14}^* \frac{\sin(2j+1)\pi ct}{2j+1} \right) + \frac{1}{4\pi} \left(\sum_{k=1}^{\infty} E_{15}^* \frac{\cos(2k+1)\pi s}{2k+1} - \sum_{k=1}^{\infty} E_{16}^* \frac{\sin(2k+1)\pi s}{2k+1} \right) \right. \right. \\
 & \left. \left. \left. \right) \right) \dot{Q}_q(t) + c^2 \left(\frac{-\pi^2 q^2 L_y}{64L_x} + \frac{1}{\pi^2} \left(\sum_{j=1}^{\infty} E_{17}^* \frac{\cos(2j+1)\pi ct}{2j+1} - \sum_{j=1}^{\infty} E_{18}^* \frac{\sin(2j+1)\pi ct}{2j+1} \right) \right. \right. \\
 & \left. \left. \left. \left(\sum_{k=1}^{\infty} E_{19}^* \frac{\cos(2k+1)\pi s}{2k+1} - \sum_{k=1}^{\infty} E_{20}^* \frac{\sin(2k+1)\pi s}{2k+1} \right) + \frac{1}{4\pi} \left(\sum_{j=1}^{\infty} E_{21}^* \frac{\cos(2j+1)\pi ct}{2j+1} - \sum_{j=1}^{\infty} E_{22}^* \frac{\sin(2j+1)\pi ct}{2j+1} \right) + \frac{1}{4\pi} \left(\sum_{k=1}^{\infty} E_{23}^* \frac{\cos(2k+1)\pi s}{2k+1} - \sum_{k=1}^{\infty} E_{24}^* \frac{\sin(2k+1)\pi s}{2k+1} \right) \right. \right. \\
 & \left. \left. \left. \right) \right) \right] Q_q(t) \Bigg] = \frac{\varpi\varphi}{\left(1 + \varpi\varphi\delta(i, j)\right)} \sin \frac{m\pi s}{L_y} \sin \frac{m\pi ct}{L_x}
 \end{aligned} \tag{3.100}$$

We shall consider a dummy parameter $\varpi^* < 1$ for any arbitrary mass ratio defined by

$$\varpi = \frac{\varpi^*}{1 + \varpi^*} \tag{3.101}$$

By using binomial theorem and truncating after second terms, one obtains

$$\varpi^* = \varpi + o(\varpi^2) \tag{3.102}$$

Considering only $o(\varpi^*)$, equation(3.103) becomes

$$\varpi = \varpi^* \tag{3.103}$$

$$\frac{1}{(1 + \varpi^* \varphi \delta(i, j))} = 1 - \varpi^* \varphi \delta(i, j) + (\varpi^*)^2 + \dots \tag{3.104}$$

on application of binomial expansion. where $|\delta(i, j)| < 1$. That is to say

$$\begin{aligned} & \left| \left(\frac{L_x L_y}{64} + \frac{1}{\pi^2} \left(\sum_{j=1}^{\infty} E_1^* \frac{\cos(2j+1)\pi ct}{2j+1} - \sum_{j=1}^{\infty} E_2^* \frac{\sin(2j+1)\pi ct}{2j+1} \right) \left(\sum_{k=1}^{\infty} E_3^* \right. \right. \right. \\ & \left. \left. \frac{\cos(2k+1)\pi s}{2k+1} - \sum_{k=1}^{\infty} E_4^* \frac{\sin(2k+1)\pi s}{2k+1} \right) + \frac{1}{4\pi} \left(\sum_{j=1}^{\infty} E_5^* \frac{\cos(2j+1)\pi ct}{2j+1} - \sum_{j=1}^{\infty} E_6^* \right. \right. \\ & \left. \left. \frac{\sin(2j+1)\pi ct}{2j+1} \right) + \frac{1}{4\pi} \left(\sum_{k=1}^{\infty} E_7^* \frac{\cos(2k+1)\pi s}{2k+1} - \sum_{k=1}^{\infty} E_8^* \frac{\sin(2k+1)\pi s}{2k+1} \right) \right| < 1 \end{aligned} \tag{3.105}$$

On putting equations (3.104) and (3.105) into equation (3.101) and rewriting it, one obtains

$$\begin{aligned} \ddot{Q}_n(t) + 2c\varpi^* \varphi & \left[1 - \varpi^* \varphi \left(\frac{L_x L_y}{64} + \frac{1}{\pi^2} \left(\sum_{j=1}^{\infty} E_1^* \frac{\cos(2j+1)\pi ct}{2j+1} - \sum_{j=1}^{\infty} E_2^* \right. \right. \right. \\ & \left. \left. \frac{\sin(2j+1)\pi ct}{2j+1} \right) \left(\sum_{k=1}^{\infty} E_3^* \frac{\cos(2k+1)\pi s}{2k+1} - \sum_{k=1}^{\infty} E_4^* \frac{\sin(2k+1)\pi s}{2k+1} \right) + \frac{1}{4\pi} \right. \\ & \left. \left(\sum_{j=1}^{\infty} E_5^* \frac{\cos(2j+1)\pi ct}{2j+1} - \sum_{j=1}^{\infty} E_6^* \frac{\sin(2j+1)\pi ct}{2j+1} \right) + \frac{1}{4\pi} \left(\sum_{k=1}^{\infty} E_7^* \frac{\cos(2k+1)\pi s}{2k+1} \right. \right. \\ & \left. \left. - \sum_{k=1}^{\infty} E_8^* \frac{\sin(2k+1)\pi s}{2k+1} \right) \right] + o(\varpi^*)^2 + \dots \left[\frac{-4mL_y}{64(n^2 - m^2)\pi} + \frac{1}{\pi^2} \left(\sum_{j=1}^{\infty} E_9^* \right. \right. \\ & \left. \left. \frac{\cos(2j+1)\pi ct}{2j+1} - \sum_{j=1}^{\infty} E_{10}^* \frac{\sin(2j+1)\pi ct}{2j+1} \right) \left(\sum_{k=1}^{\infty} E_{11}^* \frac{\cos(2k+1)\pi s}{2k+1} - \sum_{k=1}^{\infty} E_{12}^* \right. \right. \\ & \left. \left. \frac{\sin(2k+1)\pi s}{2k+1} \right) + \frac{1}{4\pi} \left(\sum_{j=1}^{\infty} E_{13}^* \frac{\cos(2j+1)\pi ct}{2j+1} - \sum_{j=1}^{\infty} E_{14}^* \frac{\sin(2j+1)\pi ct}{2j+1} \right) + \right. \\ & \left. \frac{1}{4\pi} \left(\sum_{k=1}^{\infty} E_{15}^* \frac{\cos(2k+1)\pi s}{2k+1} - \sum_{k=1}^{\infty} E_{16}^* \frac{\sin(2k+1)\pi s}{2k+1} \right) + \left[1 - \varpi^* \varphi \left(\frac{L_x L_y}{64} \right. \right. \right. \\ & \left. \left. + \frac{1}{\pi^2} \left(\sum_{j=1}^{\infty} E_1^* \frac{\cos(2j+1)\pi ct}{2j+1} - \sum_{j=1}^{\infty} E_2^* \frac{\sin(2j+1)\pi ct}{2j+1} \right) \left(\sum_{k=1}^{\infty} E_3^* \frac{\cos(2k+1)\pi s}{2k+1} \right. \right. \right. \\ & \left. \left. - \sum_{k=1}^{\infty} E_4^* \frac{\sin(2k+1)\pi s}{2k+1} \right) + \frac{1}{4\pi} \left(\sum_{j=1}^{\infty} E_5^* \frac{\cos(2j+1)\pi ct}{2j+1} - \sum_{j=1}^{\infty} E_6^* \right. \right. \\ & \left. \left. \frac{\sin(2j+1)\pi ct}{2j+1} \right) + \frac{1}{4\pi} \left(\sum_{k=1}^{\infty} E_7^* \frac{\cos(2k+1)\pi s}{2k+1} - \sum_{k=1}^{\infty} E_8^* \frac{\sin(2k+1)\pi s}{2k+1} \right) \right] + \\ & o(\varpi^*)^2 + \dots \left[\Gamma_n^2 + c^2 \left(\frac{-\pi^2 q^2 L_y}{64L_x} + \frac{1}{\pi^2} \left(\sum_{j=1}^{\infty} E_{17}^* \frac{\cos(2j+1)\pi ct}{2j+1} - \sum_{j=1}^{\infty} E_{18}^* \right. \right. \right. \end{aligned}$$

$$\begin{aligned}
 & \left. \frac{\sin(2j+1)\pi ct}{2j+1} \right) \left(\sum_{k=1}^{\infty} E_{19}^* \frac{\cos(2k+1)\pi s}{2k+1} - \sum_{k=1}^{\infty} E_{20}^* \frac{\sin(2k+1)\pi s}{2k+1} \right) + \frac{1}{4\pi} \\
 & \left(\sum_{j=1}^{\infty} E_{21}^* \frac{\cos(2j+1)\pi ct}{2j+1} - \sum_{j=1}^{\infty} E_{22}^* \frac{\sin(2j+1)\pi ct}{2j+1} \right) + \frac{1}{4\pi} \left(\sum_{k=1}^{\infty} E_{23}^* \frac{\cos(2k+1)\pi s}{2k+1} \right. \\
 & \left. - \sum_{k=1}^{\infty} E_{24}^* \frac{\sin(2k+1)\pi s}{2k+1} \right) \left. \right] Q_n(t) + \varpi^* \varphi \left[1 - \varpi^* \varphi \left(\frac{L_x L_y}{64} + \right. \right. \\
 & \left. \frac{1}{\pi^2} \left(\sum_{j=1}^{\infty} E_1^* \frac{\cos(2j+1)\pi ct}{2j+1} - \sum_{j=1}^{\infty} E_2^* \frac{\sin(2j+1)\pi ct}{2j+1} \right) \left(\sum_{k=1}^{\infty} E_3^* \frac{\cos(2k+1)\pi s}{2k+1} \right. \right. \\
 & \left. \left. - \sum_{k=1}^{\infty} E_4^* \frac{\sin(2k+1)\pi s}{2k+1} \right) + \frac{1}{4\pi} \left(\sum_{j=1}^{\infty} E_5^* \frac{\cos(2j+1)\pi ct}{2j+1} - \sum_{j=1}^{\infty} E_6^* \frac{\sin(2j+1)\pi ct}{2j+1} \right) \right. \\
 & \left. + \frac{1}{4\pi} \left(\sum_{k=1}^{\infty} E_7^* \frac{\cos(2k+1)\pi s}{2k+1} - \sum_{k=1}^{\infty} E_8^* \frac{\sin(2k+1)\pi s}{2k+1} \right) \right] + o(\varpi^*)^2 + \dots \\
 & \sum_{q=1, q \neq n}^{\infty} \left[\left(\frac{L_x L_y}{64} + \frac{1}{\pi^2} \left(\sum_{j=1}^{\infty} E_1^* \frac{\cos(2j+1)\pi ct}{2j+1} - \sum_{j=1}^{\infty} E_2^* \frac{\sin(2j+1)\pi ct}{2j+1} \right) \right. \right. \\
 & \left. \left(\sum_{k=1}^{\infty} E_3^* \frac{\sin(2k+1)\pi s}{2k+1} - \sum_{k=1}^{\infty} E_4^* \frac{\sin(2k+1)\pi s}{2k+1} \right) + \frac{1}{4\pi} \left(\sum_{j=1}^{\infty} E_5^* \frac{\cos(2j+1)\pi ct}{2j+1} - \right. \right. \\
 & \left. \left. \sum_{j=1}^{\infty} E_6^* \frac{\sin(2j+1)\pi ct}{2j+1} \right) + \frac{1}{4\pi} \left(\sum_{k=1}^{\infty} E_7^* \frac{\cos(2k+1)\pi s}{2k+1} - \sum_{k=1}^{\infty} E_8^* \frac{\sin(2k+1)\pi s}{2k+1} \right) \right] \ddot{Q}_q(t) \quad (3.106) \\
 & + 2c \left(\frac{-4mL_y}{64(q^2 - m^2)\pi} + \frac{1}{\pi^2} \left(\sum_{j=1}^{\infty} E_9^* \frac{\cos(2j+1)\pi ct}{2j+1} - \sum_{j=1}^{\infty} E_{10}^* \frac{\sin(2j+1)\pi ct}{2j+1} \right) \left(\sum_{k=1}^{\infty} E_{11}^* \frac{\cos(2k+1)\pi s}{2k+1} \right. \right. \\
 & \left. \left. - \sum_{k=1}^{\infty} E_{12}^* \frac{\sin(2k+1)\pi s}{2k+1} \right) + \frac{1}{4\pi} \left(\sum_{j=1}^{\infty} E_{13}^* \frac{\cos(2j+1)\pi ct}{2j+1} - \sum_{j=1}^{\infty} E_{14}^* \frac{\sin(2j+1)\pi ct}{2j+1} \right) \right. \\
 & \left. \frac{\sin(2j+1)\pi ct}{2j+1} \right) + \frac{1}{4\pi} \left(\sum_{j=1}^{\infty} E_{15}^* \frac{\cos(2j+1)\pi s}{2j+1} - \sum_{j=1}^{\infty} E_{16}^* \frac{\sin(2j+1)\pi s}{2j+1} \right) \left. \right] \dot{Q}_q(t) + c^2 \\
 & \left(\frac{-\pi^2 q^2 L_y}{64L_x} + \frac{1}{\pi^2} \left(\sum_{j=1}^{\infty} E_{17}^* \frac{\cos(2j+1)\pi ct}{2j+1} - \sum_{j=1}^{\infty} E_{18}^* \frac{\sin(2j+1)\pi ct}{2j+1} \right) \left(\sum_{k=1}^{\infty} E_{19}^* \frac{\cos(2k+1)\pi s}{2k+1} \right. \right. \\
 & \left. \left. - \sum_{k=1}^{\infty} E_{20}^* \frac{\sin(2k+1)\pi s}{2k+1} \right) + \frac{1}{4\pi} \left(\sum_{j=1}^{\infty} E_{21}^* \frac{\cos(2j+1)\pi ct}{2j+1} - \sum_{j=1}^{\infty} E_{22}^* \frac{\sin(2j+1)\pi ct}{2j+1} \right) \right. \\
 & \left. \frac{\sin(2j+1)\pi ct}{2j+1} \right) + \frac{1}{4\pi} \left(\sum_{k=1}^{\infty} E_{23}^* \frac{\cos(2k+1)\pi s}{2k+1} - \sum_{k=1}^{\infty} E_{24}^* \frac{\sin(2k+1)\pi s}{2k+1} \right) \left. \right] Q_q(t) = \\
 & \frac{\varpi^* \varphi}{\left(1 + \varpi^* \varphi \delta(i, j) \right)} \sin \frac{m\pi s}{L_y} \sin \frac{m\pi ct}{L_x}
 \end{aligned}$$

On expanding and retaining only $o(\varpi^{*2})$, one obtains

$$\begin{aligned}
 & \ddot{Q}_n(t) + 2c\varpi^* \varphi \left(\frac{-4mL_y}{64(n^2 - m^2)\pi} + \frac{1}{\pi^2} \left(\sum_{j=1}^{\infty} E_9^* \frac{\cos(2j+1)\pi ct}{2j+1} - \sum_{j=1}^{\infty} E_{10}^* \frac{\sin(2j+1)\pi ct}{2j+1} \right) \right. \\
 & \left(\sum_{k=1}^{\infty} E_{11}^* \frac{\cos(2k+1)\pi s}{2k+1} - \sum_{k=1}^{\infty} E_{12}^* \frac{\sin(2k+1)\pi s}{2k+1} \right) + \frac{1}{4\pi} \left(\sum_{j=1}^{\infty} E_{13}^* \frac{\cos(2j+1)\pi ct}{2j+1} \right. \\
 & \left. - \sum_{j=1}^{\infty} E_{14}^* \frac{\sin(2j+1)\pi ct}{2j+1} \right) + \frac{1}{4\pi} \left(\sum_{k=1}^{\infty} E_{15}^* \frac{\cos(2k+1)\pi s}{2k+1} - \sum_{k=1}^{\infty} E_{16}^* \frac{\sin(2k+1)\pi s}{2k+1} \right) \Bigg) \\
 & \dot{Q}_n(t) + \left[\Gamma_n^2 \left(1 - \varpi^* \varphi \left(\frac{L_x L_y}{64} + \frac{1}{\pi^2} \left(\sum_{j=1}^{\infty} E_1^* \frac{\cos(2j+1)\pi ct}{2j+1} - \sum_{j=1}^{\infty} E_2^* \frac{\sin(2j+1)\pi ct}{2j+1} \right) \right) \right. \right. \\
 & \left(\sum_{k=1}^{\infty} E_3^* \frac{\cos(2k+1)\pi s}{2k+1} - \sum_{k=1}^{\infty} E_4^* \frac{\sin(2k+1)\pi s}{2k+1} \right) + \frac{1}{4\pi} \left(\sum_{j=1}^{\infty} E_5^* \frac{\cos(2j+1)\pi ct}{2j+1} \right. \\
 & \left. - \sum_{j=1}^{\infty} E_6^* \frac{\sin(2j+1)\pi ct}{2j+1} \right) + \frac{1}{4\pi} \left(\sum_{k=1}^{\infty} E_7^* \frac{\cos(2k+1)\pi s}{2k+1} - \sum_{k=1}^{\infty} E_8^* \frac{\sin(2k+1)\pi s}{2k+1} \right) \Bigg) \\
 & + c^2 \varpi^* \varphi \left(\frac{-\pi^2 q^2 L_y}{64L_x} + \frac{1}{\pi^2} \left(\sum_{j=1}^{\infty} E_{17}^* \frac{\cos(2j+1)\pi ct}{2j+1} - \sum_{j=1}^{\infty} E_{18}^* \frac{\sin(2j+1)\pi ct}{2j+1} \right) \right. \\
 & \left(\sum_{k=1}^{\infty} E_{19}^* \frac{\cos(2k+1)\pi s}{2k+1} - \sum_{k=1}^{\infty} E_{20}^* \frac{\sin(2k+1)\pi s}{2k+1} \right) + \frac{1}{4\pi} \left(\sum_{j=1}^{\infty} E_{21}^* \frac{\cos(2j+1)\pi ct}{2j+1} \right. \\
 & \left. - \sum_{j=1}^{\infty} E_{22}^* \frac{\sin(2j+1)\pi ct}{2j+1} \right) + \frac{1}{4\pi} \left(\sum_{k=1}^{\infty} E_{23}^* \frac{\cos(2k+1)\pi s}{2k+1} - \sum_{k=1}^{\infty} E_{24}^* \frac{\sin(2k+1)\pi s}{2k+1} \right) \\
 & \left. \Bigg) \right] Q_n(t) + \varpi^* \varphi \left[1 - \varpi^* \varphi \left(\frac{L_x L_y}{64} + \frac{1}{\pi^2} \left(\sum_{j=1}^{\infty} E_1^* \frac{\cos(2j+1)\pi ct}{2j+1} - \sum_{j=1}^{\infty} E_2^* \right. \right. \right. \\
 & \left. \left. \frac{\sin(2j+1)\pi ct}{2j+1} \right) \left(\sum_{k=1}^{\infty} E_3^* \frac{\cos(2k+1)\pi s}{2k+1} - \sum_{k=1}^{\infty} E_4^* \frac{\sin(2k+1)\pi s}{2k+1} \right) + \frac{1}{4\pi} \left(\sum_{j=1}^{\infty} E_5^* \right. \right. \\
 & \left. \left. \frac{\cos(2j+1)\pi ct}{2j+1} - \sum_{j=1}^{\infty} E_6^* \frac{\sin(2j+1)\pi ct}{2j+1} \right) + \frac{1}{4\pi} \left(\sum_{k=1}^{\infty} E_7^* \frac{\cos(2k+1)\pi s}{2k+1} - \sum_{k=1}^{\infty} E_8^* \right. \right. \\
 & \left. \left. \frac{\sin(2k+1)\pi s}{2k+1} \right) \right] + o(\varpi^*)^2 + \dots \Bigg] \sum_{q=1, q \neq n}^{\infty} \left[\left(\frac{L_x L_y}{64} + \frac{1}{\pi^2} \left(\sum_{j=1}^{\infty} E_1^* \frac{\cos(2j+1)\pi ct}{2j+1} \right. \right. \right. \\
 & \left. \left. - \sum_{j=1}^{\infty} E_2^* \frac{\sin(2j+1)\pi ct}{2j+1} \right) \left(\sum_{k=1}^{\infty} E_3^* \frac{\cos(2k+1)\pi s}{2k+1} - \sum_{k=1}^{\infty} E_4^* \frac{\sin(2k+1)\pi s}{2k+1} \right) \right. \\
 & \left. + \frac{1}{4\pi} \left(\sum_{j=1}^{\infty} E_5^* \frac{\cos(2j+1)\pi ct}{2j+1} - \sum_{j=1}^{\infty} E_6^* \frac{\sin(2j+1)\pi ct}{2j+1} \right) + \frac{1}{4\pi} \left(\sum_{k=1}^{\infty} E_7^* \right. \right. \\
 & \left. \left. \frac{\cos(2k+1)\pi s}{2k+1} - \sum_{k=1}^{\infty} E_8^* \frac{\sin(2k+1)\pi s}{2k+1} \right) \right] \ddot{Q}_q(t) + 2c \left(\frac{-4mL_y}{64(q^2 - m^2)\pi} + \frac{1}{\pi^2} \right. \\
 & \left(\sum_{j=1}^{\infty} E_9^* \frac{\cos(2j+1)\pi ct}{2j+1} - \sum_{j=1}^{\infty} E_{10}^* \frac{\sin(2j+1)\pi ct}{2j+1} \right) \left(\sum_{j=1}^{\infty} E_{11}^* \frac{\cos(2j+1)\pi s}{2j+1} - \right. \\
 & \left. \sum_{j=1}^{\infty} E_{12}^* \frac{\sin(2j+1)\pi s}{2j+1} \right) + \frac{1}{4\pi} \left(\sum_{j=1}^{\infty} E_{13}^* \frac{\cos(2j+1)\pi ct}{2j+1} - \sum_{j=1}^{\infty} E_{14}^* \frac{\sin(2j+1)\pi ct}{2j+1} \right) \Bigg)
 \end{aligned}$$

$$\begin{aligned}
 & + \frac{1}{4\pi} \left(\sum_{j=1}^{\infty} E_{15}^* \frac{\cos(2j+1)\pi s}{2j+1} - \sum_{j=1}^{\infty} E_{16}^* \frac{\sin(2j+1)\pi s}{2j+1} \right) \dot{Q}_q(t) + c^2 \left(\frac{-\pi^2 q^2 L_y}{64L_x} \right. \\
 & + \frac{1}{\pi^2} \left(\sum_{j=1}^{\infty} E_{17}^* \frac{\cos(2j+1)\pi ct}{2j+1} - \sum_{j=1}^{\infty} E_{18}^* \frac{\sin(2j+1)\pi ct}{2j+1} \right) \left(\sum_{j=1}^{\infty} E_{19}^* \frac{\cos(2j+1)\pi s}{2j+1} \right. \\
 & - \sum_{j=1}^{\infty} E_{20}^* \frac{\sin(2j+1)\pi s}{2j+1} \left. \right) + \frac{1}{4\pi} \left(\sum_{j=1}^{\infty} E_{21}^* \frac{\cos(2j+1)\pi ct}{2j+1} - \sum_{j=1}^{\infty} E_{22}^* \frac{\sin(2j+1)\pi ct}{2j+1} \right) \\
 & + \frac{1}{4\pi} \left(\sum_{j=1}^{\infty} E_{23}^* \frac{\cos(2j+1)\pi s}{2j+1} - \sum_{j=1}^{\infty} E_{24}^* \frac{\sin(2j+1)\pi s}{2j+1} \right) \left. \right] Q_q(t) = \varpi^* \varphi \sin \frac{m\pi s}{L_y} \\
 & \sin \frac{m\pi ct}{L_x}
 \end{aligned} \tag{3.107}$$

Applying the method of Struble technique to equation (3.108), one obtains

$$\ddot{Q}_n(t) + \Theta_n^2 Q_n(t) = \varpi^* \varphi g \sin \frac{m\pi s}{L_y} \sin \frac{m\pi ct}{L_x} \tag{3.108}$$

where

$$\begin{aligned}
 \Theta_n = & \left[\Gamma_n - \frac{1}{2\Gamma_n} \left(\varpi^* \varphi \left(\frac{L_x L_y}{64} + \frac{1}{4\pi} \left(\sum_{k=1}^{\infty} E_7^* \frac{\cos(2k+1)\pi s}{2k+1} - \sum_{k=1}^{\infty} E_8^* \frac{\sin(2k+1)\pi s}{2k+1} \right) \right) - \right. \\
 & \left. c^2 \varpi^* \varphi \left(\frac{-\pi^2 q^2 L_y}{64L_x} + \frac{1}{4\pi} \left(\sum_{k=1}^{\infty} E_{23}^* \frac{\cos(2k+1)\pi s}{2k+1} - \sum_{k=1}^{\infty} E_{24}^* \frac{\sin(2k+1)\pi s}{2k+1} \right) \right) \right] \tag{3.109}
 \end{aligned}$$

is the modified frequency for simply supported orthotropic rectangular plate.

$$Q_n(t) = \frac{\varpi^* \varphi g}{\Theta_n} \sin \frac{m\pi s}{L_y} \times \left[\frac{\Theta_n \sin \frac{m\pi c t}{L_x} - \left(\frac{m\pi c}{L_x} \right) \sin \Theta_n t}{\left(\frac{m\pi c}{L_x} \right)^2 - \Theta_n^2} \right] \tag{3.110}$$

On further substitution, equation (3.1) becomes

$$W(x, y, t) = \frac{\varpi^* \varphi g}{\Theta_n} \sin \frac{m\pi s}{L_y} \times \left[\frac{\Theta_n \sin \frac{m\pi c t}{L_x} - \left(\frac{m\pi c}{L_x} \right) \sin \Theta_n t}{\left(\frac{m\pi c}{L_x} \right)^2 - \Theta_n^2} \right] \times \sin \frac{m\pi x}{L_x} \sin \frac{m\pi y}{L_y} \tag{3.111}$$

is the transverse displacement response to a moving mass of a simply supported orthotropic rectangular plate.

4 Discussion of the Analytical Solutions

For this undamped system, it is desirable to examine the phenomenon of resonance. From equation (3.97), it is clearly shown that the simply supported orthotropic rectangular plate on constant elastic foundation and traverse by moving distributed force with uniform speed reaches a state of resonance whenever

$$\Gamma_n = \frac{m\pi c}{L_x} \tag{4.1}$$

while equation (3.112) shows that the same simply supported orthotropic rectangular plate under the action of a moving mass experiences resonance when

$$\Theta_n = \frac{m\pi c}{L_x} \tag{4.2}$$

where

$$\Theta_n = \Gamma_n \left[1 - \frac{1}{2\Gamma_n^2} \left(\varpi^* \varphi \left(\frac{L_x L_y}{64} + \frac{1}{4\pi} \left(\sum_{k=1}^{\infty} E_7^* \frac{\cos(2k+1)\pi s}{2k+1} - \sum_{k=1}^{\infty} E_8^* \frac{\sin(2k+1)\pi s}{2k+1} \right) \right) - c^2 \varpi^* \varphi \left(\frac{-\pi^2 q^2 L_y}{64 L_x} + \frac{1}{4\pi} \left(\sum_{k=1}^{\infty} E_{23}^* \frac{\cos(2k+1)\pi s}{2k+1} - \sum_{k=1}^{\infty} E_{24}^* \frac{\sin(2k+1)\pi s}{2k+1} \right) \right) \right] \quad (4.3)$$

Comparing equations (4.1) and (4.2), one obtains

$$\Theta_n = \Gamma_n \left[1 - \frac{1}{2\Gamma_n^2} \left(\varpi^* \varphi \left(\frac{L_x L_y}{64} + \frac{1}{4\pi} \left(\sum_{k=1}^{\infty} E_7^* \frac{\cos(2k+1)\pi s}{2k+1} - \sum_{k=1}^{\infty} E_8^* \frac{\sin(2k+1)\pi s}{2k+1} \right) \right) - c^2 \varpi^* \varphi \left(\frac{-\pi^2 q^2 L_y}{64 L_x} + \frac{1}{4\pi} \left(\sum_{k=1}^{\infty} E_{23}^* \frac{\cos(2k+1)\pi s}{2k+1} - \sum_{k=1}^{\infty} E_{24}^* \frac{\sin(2k+1)\pi s}{2k+1} \right) \right) \right] = \frac{m\pi c}{L_x} \quad (4.4)$$

5 Graphs of the Numerical Solutions

To illustrate the analysis presented in this work, orthotropic rectangular plate is taken to be of length $L_y = 0.923m$, breadth $L_x = 0.432m$ the load velocity $c=0.8123$ m/s and $s = 0.4m$.The results are presented on the various graphs below for the simply supported boundary conditions.

5.1 Graphs for Simply Supported Boundary Conditions

Fig. 2 and 3 display the effect of rotatory inertia R_o on the deflection profile of simply supported orthotropic rectangular plate under the action of load moving at constant velocity in both cases of moving distributed forces and moving distributed masses respectively. The graphs show that the response amplitude decreases as the value of rotatory inertia R_o increases.

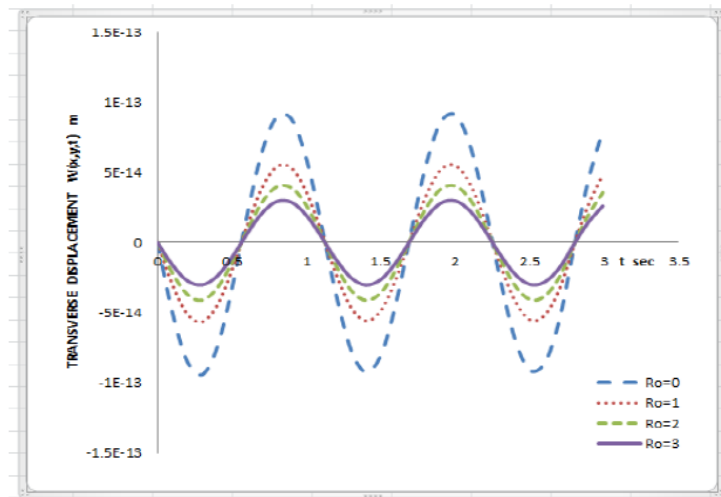

Fig. 2. Displacement profile of simply supported orthotropic rectangular plate with varying R_o and traversed by moving force

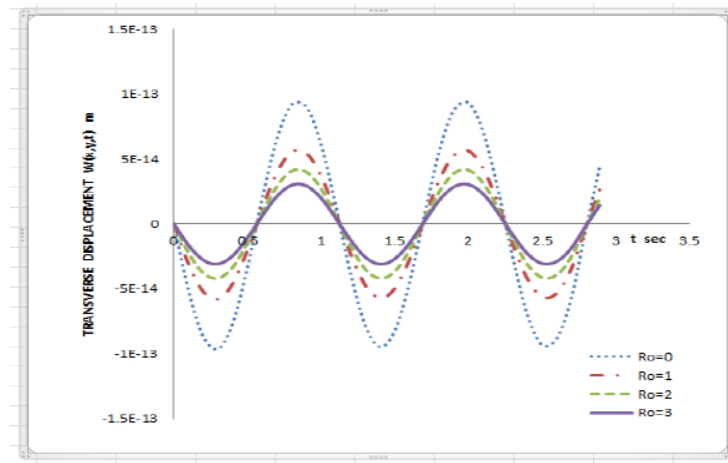

Fig. 3. Displacement profile of simply supported orthotropic rectangular plate with varying R_o and traversed by moving mass

Fig. 4 and 5 display the effect of foundation modulus K_o on the deflection profile of simply supported orthotropic rectangular plate under the action of load moving at constant velocity in both cases of moving distributed forces and moving distributed masses respectively. The graphs show that the response amplitude decreases as the value of foundation modulus K_o increases.

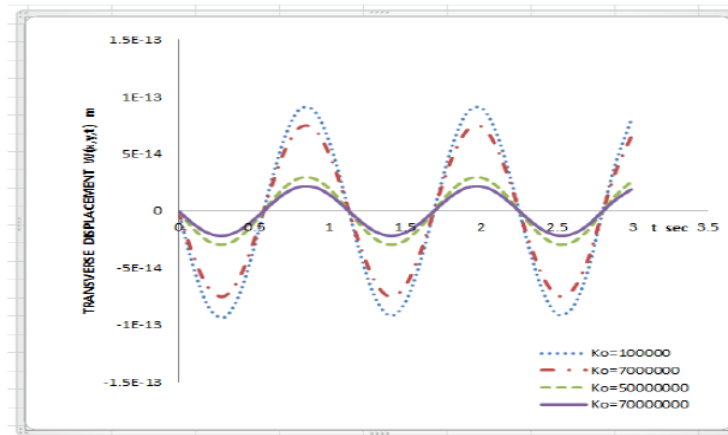

Fig. 4. Displacement profile of simply supported orthotropic rectangular plate with varying K_o and traversed by moving force

Fig. 6 and 7 display the effect of shear modulus G_o on the deflection profile of simply supported orthotropic rectangular plate under the action of load moving at constant velocity in both cases of moving distributed forces and moving distributed masses respectively. The graphs show that the response amplitude decreases as the value of shear modulus G_o increases.

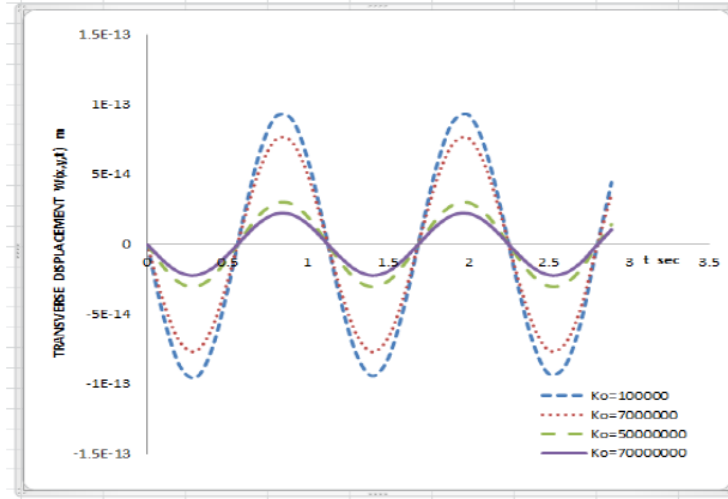

Fig. 5. Displacement profile of simply supported orthotropic rectangular plate with varying K_o and traversed by moving mass

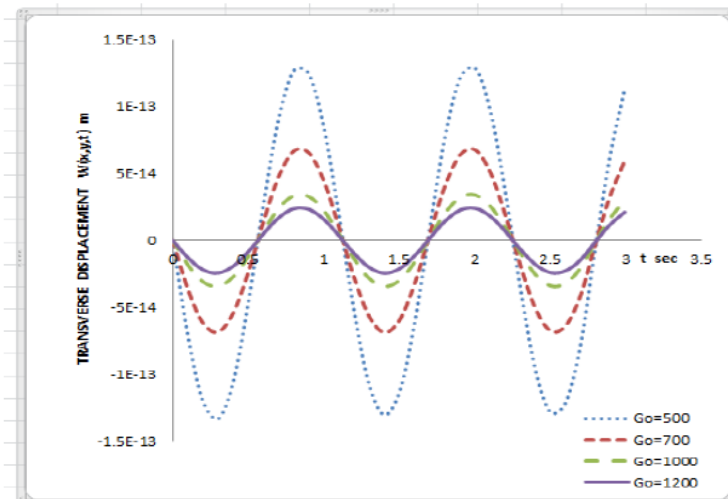

Fig. 6. Displacement Profile of simply supported orthotropic rectangular plate with varying G_o and traversed by moving force

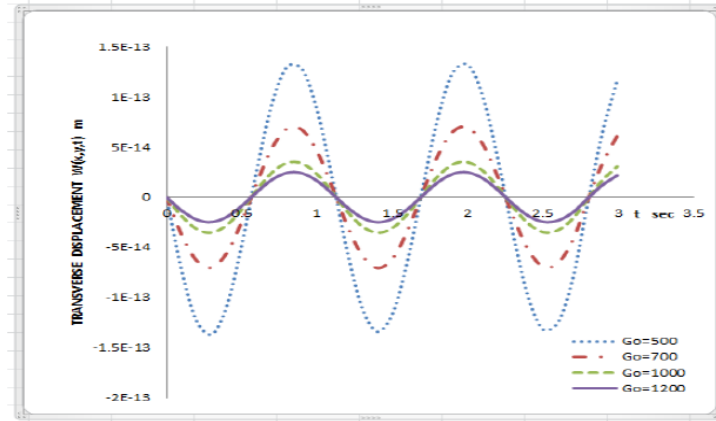

Fig. 7. Displacement profile of simply supported orthotropic rectangular plate with varying G_o and traversed by moving mass

Fig. 8 and 9 display the effect of flexural rigidity of the plate along x-axis D_x on the deflection profile of simply supported orthotropic rectangular plate under the action of load moving at constant velocity in both cases of moving distributed forces and moving distributed masses respectively. The graphs show that the response amplitude decreases as the value of flexural rigidity D_x increases.

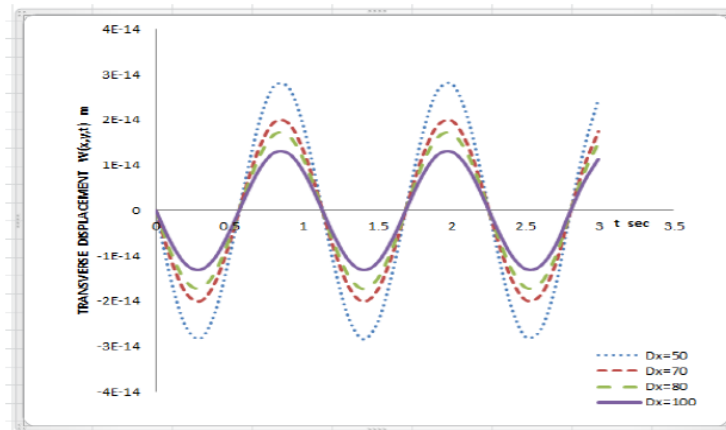

Fig. 8. Displacement profile of simply supported orthotropic rectangular plate with varying D_x and traversed by moving force

Fig. 10 and 11 display the effect of flexural rigidity of the plate along y-axis D_y on the deflection profile of simply supported orthotropic rectangular plate under the action of load moving at constant velocity in both cases of moving distributed forces and moving distributed masses respectively. The graphs show that the response amplitude decreases as the value of flexural rigidity D_y increases.

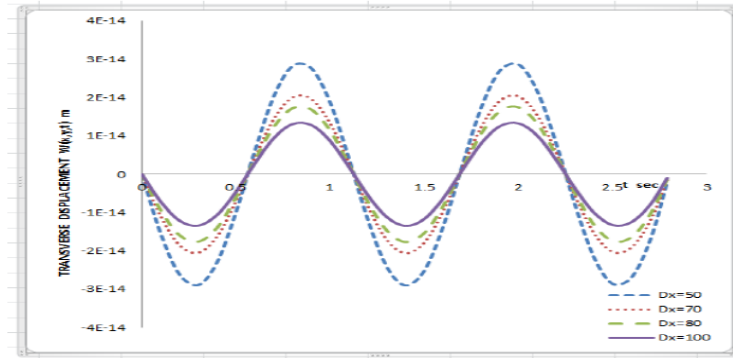

Fig. 9. Displacement Profile of simply supported orthotropic rectangular plate with varying D_x and traversed by moving mass

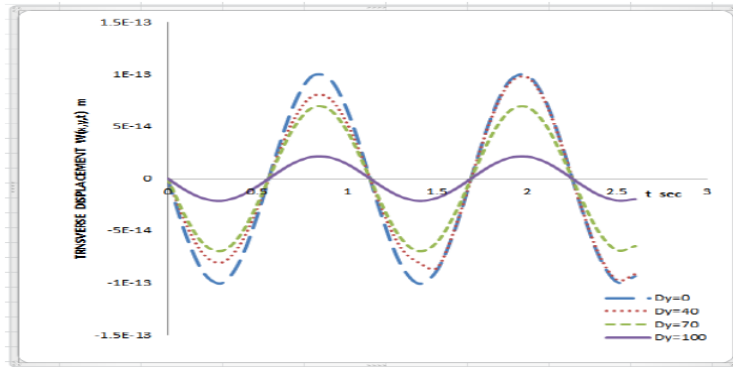

Fig. 10. Displacement profile of simply supported orthotropic rectangular plate with varying D_y and traversed by moving force

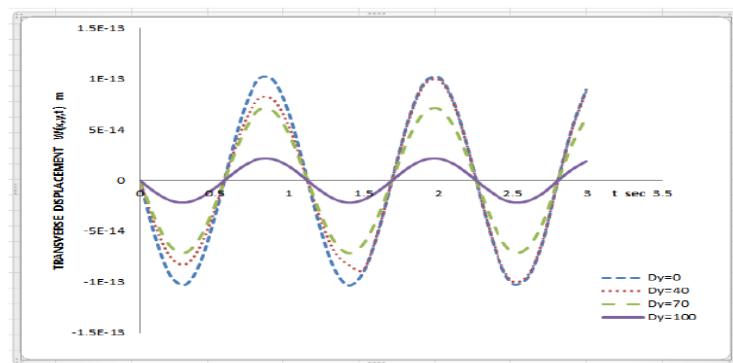

Fig. 11. Displacement profile of simply supported orthotropic rectangular plate with varying D_y and traversed by moving mass

Fig. 12 displays the comparison between moving force and moving mass for fixed values of R_o , G_o , K_o , D_x and D_y .

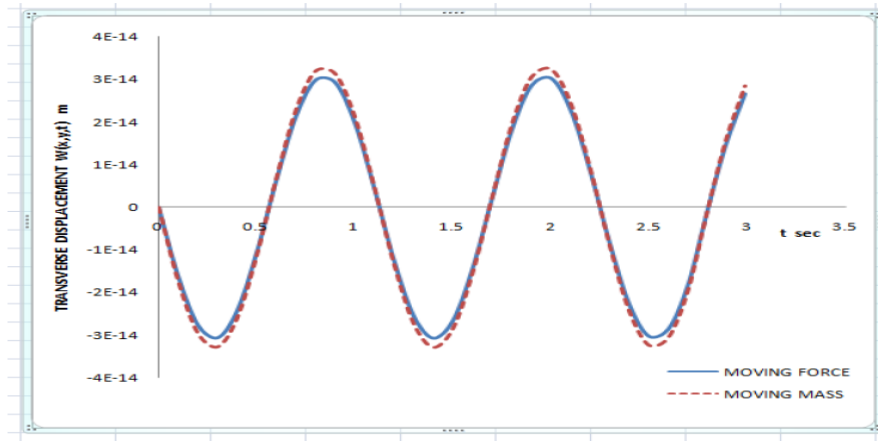

Fig. 12. Displacement profile of comparison between moving force and moving mass

6 Conclusion

In this work, the problem of dynamic behavior of simply supported orthotropic rectangular plates resting on bi-parametric foundation has been studied. The closed form solutions of the fourth order partial differential equations with variable and singular coefficients governing the orthotropic rectangular plates is obtained for both cases of moving force and moving mass using a solution technique that is based on the separation of variables which was used to remove the singularity in the governing fourth order partial differential equation and thereby reducing it to a sequence of coupled second order differential equations. The modified Struble's asymptotic technique and Laplace transformation techniques are then employed to obtain the analytical solution to the two-dimensional dynamical problem.

The solutions are then analyzed. The analyses show that, for the same natural frequency and the critical speed for the moving mass problem is smaller than that of the moving force problem. Resonance is reached earlier in the moving mass system than in the moving force problem. That is to say the moving force solution is not an upper bound for the accurate solution of the moving mass problem.

The results in plotted curves show that as the rotatory inertia correction factor R_o increases, the amplitudes of plates decrease for both cases of moving force and moving mass problems. The flexural rigidities along both the x-axis D_x and y-axis D_y increase, the amplitudes of plates decrease for both cases of moving force and moving mass problems. As the shear modulus G_o and foundation modulus K_o increase, the amplitudes of plates decrease for both cases of moving force and moving mass problems.

It is shown further from the results that for fixed values of rotatory inertia correction factor, flexural rigidities along both x-axis and y-axis, shear modulus and foundation modulus, the amplitude for the moving mass problem is greater than that of the moving force problem which implies that resonance is reached earlier in moving mass problem than in moving force problem of simply supported orthotropic rectangular plates resting on bi-parametric foundation.

Competing Interests

Authors have declared that no competing interests exist.

References

- [1] Shadnam MR, Mofid M, Akin JE. On the dynamic response of rectangular plate with moving mass. *Thin-walled Structures*. 2001;39:797 - 806.
- [2] Euler L. De Vibratorio Tympanorum, *Novi Comm. Acad. Petropolitanae*, t. 1766(1767);10:243-260.
- [3] Chladni EFF. *Die Akustik*, Leipzig; 1802.
- [4] Bernoulli J. Essai theoretique sur les vibrations des plaques elastiques. Rectangulaires Et Litres, *Nova Acta Acad. Sc. Petropolitanae* 1789;5:197-219.
- [5] Malhotra SK, Ganesan N, Veluswami MA. Vibrations of orthotropic square plates having variable thickness (Parabolic Vibration). *Journal of Sound and Vibration*. 1987;119:184-188.
- [6] Ashour AS. A semi-analytical solution of the flexural vibration of orthotropic plates of variable thickness. *Journal of Sound and Vibration*. 2001;240(2001):431-445.
- [7] Bert, Malik. Free vibration analysis of tapered rectangular plates by differential quadrature method: A semi - analytical approach. *Journal of Sound and Vibration*. 1996;190(1996):41-63.
- [8] Maljaars J, Dooren Van F, Kolstein MH. Fatigue assessment for deck plates in orthotropic bridge decks. *Steel Construction - Design and Research*, 2012;5(2):93-100. DOI: 10.1002/stco.201210011
- [9] Awodola TO. On the vibrations of moving mass of elastically supported plate resting on bi-parametric foundation with stiffness variation. *Journal of the Nigerian Association of Mathematical Physics*. 2015;29:65-80.
- [10] Szekrenyes A. Interface fracture in orthotropic composite plates using second-order shear deformation theory. *International Journal of Damage Mechanics*; 2013;22(8):1161-1185.
- [11] Kadari B. Buckling analysis of orthotropic nanoscale plates resting on elastic foundations. *Journal of Nano Research*. 2018;55.
- [12] Hu XF, Yao WA. Vibration solutions of rectangular orthotropic plates by symplectic geometry method. 2012;211-221.
- [13] Alshaya A, John H, Rowlands R. Stresses and strains in thick perforated orthotropic plates. *Journal of Engineering Mechanics*. 2016;142(11):10.
- [14] Gbadeyan JA, Dada MS. Dynamic response of plates on pasternak foundation to distributed moving loads. *Journal of Nigerian Mathematical Physics*. 2001;5:185-200.
- [15] Barile C, Casavola C, Vimalathithan PK, Pugliese M, Maiorano V. Thermomechanical and morphological studies of CFRP tested in different environmental conditions. *Materials*. 2019;12(1):63:1-16.
- [16] Guo XY, Wang YL, Huang PY, Zheng XH, Yang Y. Fatigue life prediction of reinforced concrete beams strengthened with CFRP: Study based on an accumulative damage mode. *Polymers*. 2019;11(1):130:1-18.
- [17] Guo XY, Yu B, Huang PY, Zheng XH, Zhao C. J-integral approach for main crack propagation of RC beams strengthened with prestressed CFRP under cyclic bending load. *Engineering Fracture Mechanics*. 2018;200:465-478.

- [18] Hosseini A, Ghafoori E, Al-Mahaidi R, Zhao XL, Motavalli M. Strengthening of a 19th-century roadway metallic bridge using non-prestressed bonded and prestressed unbonded CFRP plates. *Construction and Building Materials*. 2019;209:240-259.
- [19] Ju M, Oh H, Sim J. Indirect fatigue evaluation of CFRP-reinforced bridge deck slabs under variable amplitude cyclic loading. *KSCE Journal of Civil Engineering*. 2017;21(5):1783-1792.
- [20] Li LZ, Chen T, Zhang NX. Test on fatigue repair of central inclined cracked steel plates using different adhesives and CFRP, prestressed and non-prestressed. *Composite Structures*. 2019;216:350-359.
- [21] Liang HJ, Li S, Lu YY, Yang T. Reliability analysis of bond behaviour of CFRP-concrete interface under wet-dry cycles. *Materials*. 2018;11(5):741:1-14.
- [22] Xin Yuan, Wei Zheng, Chaoyu Zhu, Baijian Tang. Fatigue performance and life prediction of CFRP plate in the RC bridge roof reinforcement. *Latin American Journal of Solids and Structures*. 2020;17(2):e250.

© 2020 Awodola and Adeoye; This is an Open Access article distributed under the terms of the Creative Commons Attribution License (<http://creativecommons.org/licenses/by/4.0>), which permits unrestricted use, distribution and reproduction in any medium, provided the original work is properly cited.

Peer-review history:

The peer review history for this paper can be accessed here (Please copy paste the total link in your browser address bar)

<http://www.sdiarticle4.com/review-history/57775>